



Creating Security Solutions.  
*With Care.*

# VUpoint Cube Indoor IP Camera



**Model: RVCM11H**



**Installation Guide**

## Safety Precautions

These instructions are intended to ensure that the user can use the product correctly to avoid danger or property loss.

### **WARNINGS:**

- Installation or usage of this product that is not in accordance with the intended use as defined by the supplier and as described in the instructional materials can result in damage, injury, or death.
- Make sure this product is not accessible by children and those for whom operation of the system is not intended.
- All installation and operation should conform to your local electrical safety codes. The power shall conform to the requirement in the SELV (Safety Extra Low Voltage) and the Limited power source is rated 12V DC in the IEC60950-1.
- If the device is permanently connected to an electrical power supply, then the connection should include an easily-accessible disconnection device, such as a circuit breaker. Do not connect the two power supplying sources to the device at the same time; it may result in device damage!
- Do not ever attempt to repair your device by yourself, as doing so could result in damage, injury or death – always contact your installer / supplier agent for service.

### **CAUTIONS:**

- Make sure the power supply voltage is correct before using the camera.
- Do not drop the camera or subject it to physical shock.
- Do not touch sensor modules with fingers. If cleaning is necessary, use a clean cloth with a bit of ethanol and wipe it gently.
- Do not aim the camera lens at the strong light such as sun or incandescent lamp. The strong light can cause fatal damage to the camera.
- The sensor may be burned out by a laser beam, so when any laser equipment is being used, make sure that the surface of the sensor not be exposed to the laser beam.
- Do not place the camera in extremely hot, cold temperatures (the operating temperature should be between  $-10^{\circ}\text{C} \sim +50^{\circ}\text{C}$ ).
- To avoid heat accumulation, good ventilation is required for a proper operating environment.
- Keep the camera away from water and any liquid.
- While shipping, the camera should be packed in its original packing.

**NOTE:** We assume no liability or responsibility for all the fires or electrical shock caused by improper handling or installation. We are not liable for any problems caused by unauthorized modification or attempted repair.

## Introduction

RISCO Group presents VUpoint, a revolutionary live video verification solution which seamlessly integrates IP Cameras within RISCO's professional security systems. Powered by the RISCO Cloud (RISCO Application Server), VUpoint provides an unprecedented level of security and live video monitoring capabilities to monitoring stations and end-users alike. The RISCO cube indoor IP Camera is an important part of this solution and is easily controlled through RISCO's intuitive Web and Smartphone applications.

## Features

- Plug & Play installation
- 1.3" Megapixel
- Color HD
- SD card slot for local storage
- WiFi
- IR LED (7-10m)

## Components and Accessories

RISCO IP camera and mounting bracket:



Electrical power adapter (not supplied with the camera) and installation accessories bag:



Installation guide:



## Minimum Internet Network Requirements:

- 750 Kbps upload speed (per camera)
- 5 Mbps download speed

**RECOMMENDATION** – You can install more than one camera with the minimum recommended requirement (750 Kbps for each camera), but note that viewing multiple cameras in parallel may reduce the refresh speed and picture quality.

## IP Camera Components and Dimensions

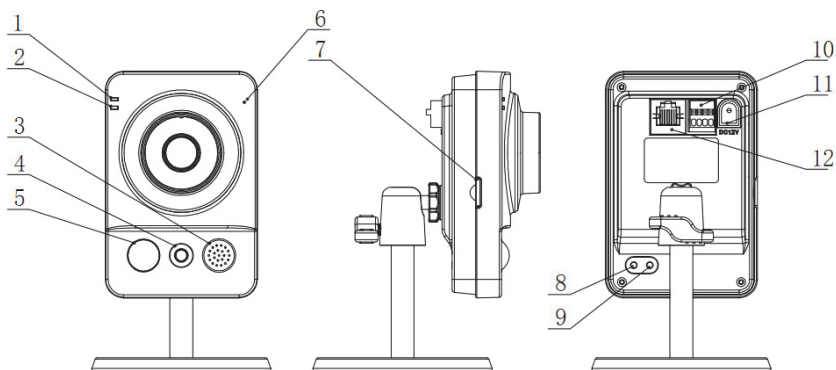
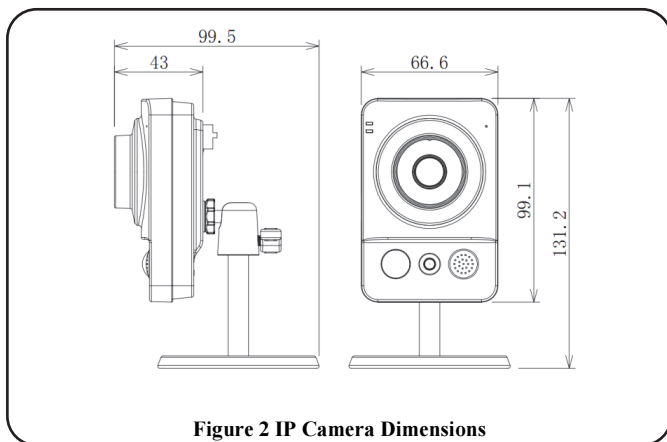

Figure 1 IP Camera Components

Label	Port Name	Indicator	Connector	Description
1	Power indicator light	POWER	/	<ul style="list-style-type: none"> <li>When camera boots up – Green light turns on.</li> <li>When camera is upgrading – Green light flashes. Interval is 0.5s.</li> <li>When camera is in alarm – Green light flashes. Interval is 0.2s.</li> </ul>
2	Network indicator light	NET	/	<ul style="list-style-type: none"> <li>Wired network connection - Red light is on.</li> <li>Wireless network connection - Green light is on.</li> </ul>
3	Speaker	/	/	Output audio signal (This function is optional).
4	IR LED	Red LED	/	During darkness, the IR LED turns on automatically.
5	N/A	N/A	N/A	N/A

Label	Port Name	Indicator	Connector	Description
6	Microphone	/	/	Directly receive audio signal (This function is optional).
7	Micro SD card	Micro SD	Micro SD card slot	SD card storage. Micro SD card requirements: Type: class 4 Memory: up to 64GB. <b>NOTE:</b> Adding micro SD card enables the ability of recording video clips. When entering/replacing micro SD card, camera should be powered off.
8	Reset button	Reset	/	Restore factory default setup. When system is running normally, press the RESET button for at least 5 seconds, system can restore factory default setup.
9	WPS button	WPS	Fast wireless connection	Press the WPS button of the router and the device respectively for at least 2 seconds. Usually the device connects to the router within 1 minute. Please note that this is for wireless router with WPS functionality only.
10	N/A	N/A	N/A	N/A
11	Power port	DC12V	/	Input DC 12V power.
12	Network port	LAN	Ethernet port	Connects to standard Ethernet cable.



**Figure 2 IP Camera Dimensions**

# IP Camera Installation

After reading the installation instructions and before installing your IP camera, prepare a plan for mounting the IP camera at your protected site. Correct placement of your IP camera is crucial for optimal security-monitoring performance. First, determine which areas need to be protected and then map out the most optimal areas for installing your IP camera.

**IMPORTANT!** – Please make a record of the MAC address located on the box or on the back cover of the IP camera before installation. You may need it during the network connection stage.

MAC address



**RISCO** 14 Hachoma St.  
Rishon Le Zion,  
ISRAEL

CE 557811778  
FC

Barcode  
P/N: RVC11H0000A  
IP Cam: Indoor, Hyb, 1.3MP, POE, 2.4G  
INPUT: 12V, 0.5A FCC ID: SVNIPC-K100

Barcode  
MAC: AA:BB:CC:DD:EE:FF

Barcode  
S/N: XXXXXXXXXXXXXXXX

Made in China

## Mounting the IP Camera

The IP camera support two mounting options; ceiling and wall mount (see Figure 3 and Figure 4, below).

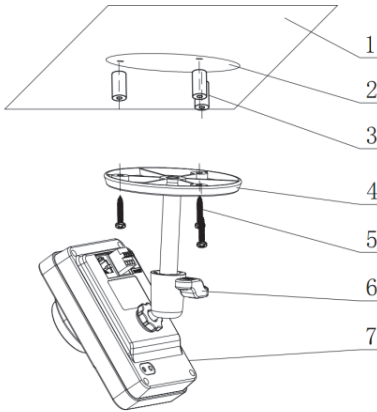

Figure 3 Ceiling Mount

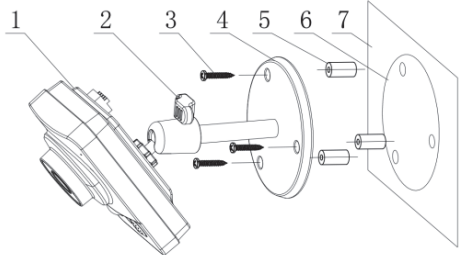

Figure 4 Wall Mount

**IMPORTANT-** Please make sure the installation surface can support at least 3 times the weight of the camera and the bracket.

Step	Description
1	Place the installation positioning template on the installation surface such as ceiling or wall.
2	Make holes in the installation surface according to the installation positioning template.
3	Insert the expansion bolts from the accessories bag into the holes you just made.
4	Position the IP camera base over the holes
5	Use the screws from the accessories bag to secure the IP camera firmly.
6	Loosen the adjust knob and adjust the IP camera to the correct surveillance position according to your actual requirements.
7	Secure the adjust knob to fix the IP camera.

## Powering-up the IP Camera

1. Connect the provided electrical power adapter to the Power port on the IP camera.
2. Connect the power adapter to an electrical outlet. When the IP camera boots up, the GREEN power indicator light turns on.

## Connecting the IP Camera to the Network

The IP camera supports several network connection options including LAN and Wireless.

### Connecting to a LAN Network

Connecting the IP camera to a network using the LAN (Local Area Network) enables easy connection and setup with compatible APs (Access Points), e.g. gateway or router.

1. Connect the incoming network cable to the Network port on the IP camera.
2. Wait just a few minutes while the IP camera automatically connects to the RISCO Cloud. The RED network indicator light indicates that your IP camera is now ready for defining camera settings (Refer to Defining IP Camera Settings).

## Connecting to a Wireless Network using WPS

Connecting the IP camera to a wireless network using WPS (Wi-Fi Protected Setup) requires that the router and Operating System supports WPS functionality.

---

**NOTE** – Some routers have a virtual button on their management software. (Refer to the router’s documentation for details about using its WPS functions).

---

1. Once the power cord is connected, wait for 5 minutes for the camera to boot up.
2. Press and hold down the WPS button on the IP camera and the WPS button on the router respectively for 2 seconds. The GREEN network indicator light indicates that your IP camera is now ready for defining camera settings (Refer to Defining IP Camera Settings).

## Connecting to a Wireless Network using the RISCO Cloud

Connecting the IP camera to a wireless network using the RISCO Cloud (RISCO Application Server) requires that you first physically connect the IP camera to the router and then, from the RISCO Cloud Installer Application, define the IP camera settings and establish a wireless connection. Once a wireless connection has been established the IP camera can then be disconnected from the router and installed.

1. Connect the incoming network cable to the Network port on the IP camera.
2. Wait just a few minutes while the IP camera automatically connects to the RISCO Cloud (RISCO Application Server). The RED network indicator light indicates that your IP camera is now ready for defining camera settings (Refer to Defining IP Camera Settings).
3. Once a wireless connection has been established, disconnect the IP camera from the router and install it anywhere within the monitored area.

---

### **NOTES:**

1. In order to connect the IP camera to RISCO Cloud via UPnP, the router should be UPnP certified. If your router is not UPnP certified, we recommend not to use UPnP and to open camera ports manually in the router (See Troubleshooting section for more information).
  2. The IP camera cannot be connected to more than one router.
-



# IP Cameras and the RISCO Cloud Installer Application

The RISCO Cloud Installer Application provides an interface to your control panel from a local or remote PC via the Web. This enables you to add IP cameras and define camera and event alarm trigger settings.

**IMPORTANT** – A control panel must first be defined in RISCO Cloud in order to accept IP cameras and define camera settings (Refer to the RISCO Cloud Installer Application Manual)

## Defining IP Camera Settings

Once you have connected the IP camera to the network (refer to, Connecting the IP Camera to the Network) you can define the camera settings.

**To define IP camera settings:**

1. Log into the Installer Administration application using the Web page address supplied by your service provider and enter your user name and password.

**NOTE** – It is recommended to use Google Chrome or Mozilla Firefox to log into the Installer Administration application.

2. Select the Control Panels List link. The Control Panels List page is displayed.

Users List | Service Providers List | Control Panels List | Statistics | Services Info | Logout  
Customization | Configurations | Control Panels Groups | Email & SMS Settings | SMS/Email Traffic | Licenses

Control Panels from group All Panels (Page 1/4)

Find Control Panels where Last Name begins with [ ] Find

CP Login ID	Web Login ID	First Name	Last Name	Cell Phone	Provider (1st)	Account	Last Connected Time	Online?
TCONNECT203							7/17/2012 9:39:48 AM	No
22400000123							4/19/2012 5:34:47 PM	No
22400048768								Never
22400036472							5/14/2012 3:26:34 PM	No
22400000014							4/25/2012 9:00:11 AM	No
22400065764							5/21/2012 3:25:56 PM	No
22400000010							4/30/2012 1:11:16 PM	No
22400066013							5/2/2012 4:55:14 PM	No
22400000012							9/27/2012 1:01:38 PM	No
22400065725							9/19/2012 12:27:16 PM	No

New Customer

Note: A new panel shall be automatically assigned to the currently selected CP group.

10 >>>

Figure 5 Control Panels List Page

3. From the Control Panels List page, select the Control Panel you wish to view. The Control Panels Update page is displayed.

**Figure 6 Control Panel Update Page**

- Click the Network Cameras link in the left-hand column; the IP Camera List page is displayed.

**Figure 7 IP Cameras List**

- Click Add Camera; the Add Camera dialog box is displayed.

**Figure 8 Add Camera**

- Define the following fields in the Add Camera dialog box.

Field	Description
<b>Label</b>	Enter a name for the camera
<b>Partitions</b>	Select the partition(s) from the list of defined partitions
<b>Type</b>	Choose the RISCO camera type (for ON VIF or Generic camera type settings, refer to the RISCO Cloud Installer Application Manual)
<b>MAC Address</b>	Enter the MAC address into this field. The MAC address (media access control address) is the unique identifier assigned to the IP camera for communications on the physical network. <b>NOTE:</b> The MAC address is case sensitive and should be entered exactly as it is shown on the box or on the back cover of the IP camera, e.g. AA:BB:CC:DD:EE:FF

7. Click Add.

If the “Camera was identified successfully” message is displayed, go straight to step 8.

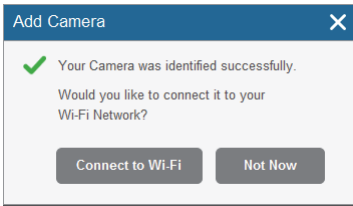

**Figure 9 Camera was identified successfully message**

If an “unable to configure Internet Access”, “UPnP Client Error” or similar message is displayed, refer to the Troubleshooting section.

---

**NOTE** – This message is only relevant for IP cameras that are physically connected to the LAN network via the router.

---

8. Select one of the following options:

**Connect to Wi-Fi** – to establish a wireless network connection (go to step 9 to connect the IP camera to the wireless network).

**Not Now** – to establish a LAN network connection (skip the wireless network connection steps 9, 10 and 11 and connect the IP camera to the LAN network).

9. If you selected the “Connect to Wi-Fi” option, a list of available wireless networks is displayed.



**Figure 10 List of available wireless networks**

10. Select a wireless network from the available list and click Connect.

**NOTE** – If your network is password protected, a password must be entered into the displayed password screen.

11. Click OK to establish the wireless connection (Refer to Connecting to a Wireless Network using the RISCO Cloud).

**IMPORTANT** – Once a wireless connection has been established, don't forget to disconnect the IP camera Ethernet cable from the router.

12. Once the “camera is ready for use” message is displayed, click OK. The defined IP camera is displayed in the IP Cameras page.

## IP Cameras

The screenshot shows a user interface with two tabs: 'Cameras' (selected) and 'Triggers'. Below the tabs is a '+ Add Camera' button. The main area contains a table with the following data:

Label	Partition	Type	MAC Address	Wi-Fi	Actions
Main Entrance cam	Lobby Floor	RISCO	00-10-5A-44-12-B5	Connected	
Front yard cam	Lobby Floor, Storage Rooms	RISCO	00-10-2B-36-11-18	Connect	
Lobby cam	Lobby Floor	Generic	11-10-5A-44-12-B5	Connect	
Living Room	Storage Rooms	ONVIF	07-10-5A-4A-28-B6	Connected	
Second Floor north cam	Storage Rooms	ONVIF	00-10-5A-44-12-B5	Connected	
Basement	Sun Microsystems	RISCO	03-10-5A-44-12-B5	Connected	

Figure 11 IP Camera List

**NOTE** – You also have the option to edit or delete the selected IP camera.

## Defining Camera Trigger Settings

Any event from the following list can be defined to trigger an alarm.

Partition Events			
Fire Alarm	Panic Alarm	Medical Alarm	Alarm
Full Arm	Part Arm	Disarmed	Duress
Tamper	24 HR-X Alarm	Water Alarm	Gas Alarm
Environ. Alarm	No Motion Alarm	Exit Alarm	Low Temperature
Detector Events			
Alarm	Zone Bypassed	Zone Un-bypassed	Zone Tamper

## To define camera trigger settings:

1. From the Control Panel Cameras page, click the Triggers tab, the Camera Triggers List page is displayed.

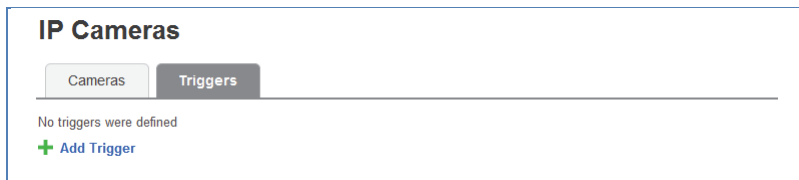

Figure 12 Camera Triggers List

2. Click Add Trigger; the Add Triggers dialog box appears.

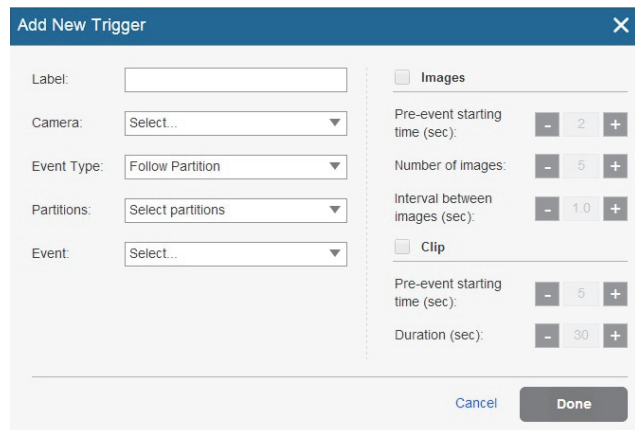

Figure 13 Add Trigger

3. Define the following fields in the Add Trigger dialog box:

Field	Description	Event Type
Label	Enter a name for the camera trigger	Partition and Detector events
Camera	Choose a camera from the list	Partition and Detector events
Event Type	Choose an event type from the list	Partition and Detector events
Event	Choose the event from the list, e.g. alarm, duress, etc.	Partition and Detector events

Additional fields are displayed in the Add Trigger dialog box according to the event type that you selected (see examples below for Partition and Detector event types).

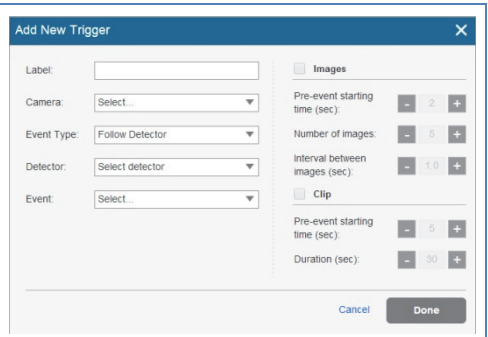
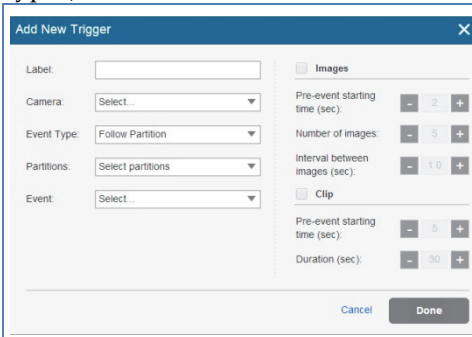

Figure 14 Add Partition Event Trigger

Figure 15 Add Detector Event Trigger

4. Define the following fields in the Add Trigger dialog box according to the event type that you selected.

Field	Description	Event Type
<b>Partition(s)</b>	Select the partition(s) from the list. <b>NOTE</b> – Only partitions associated with the camera are displayed.	Partition events only
<b>Detectors</b>	Select the detector from the list	Detector events only

5. Define the following image (still) and clip (video) definitions:

Field	Description
<b>Images (still)</b>	<b>Pre-event starting time (sec)</b> – time, before the actual event occurred, to start displaying still images. <b>Number of images</b> – number of still images to display. <b>Interval between images (sec)</b> – time required between each still image.
<b>Clips (video)</b>	<b>Pre-event starting time (sec)</b> – time, before the actual event occurred, to start displaying video clip. <b>Duration (sec)</b> – total duration of the video clip <b>NOTE</b> – These fields are currently locked and the default parameters cannot be changed.

- Once finished, click Done. The defined camera trigger is displayed in the Camera Triggers List page.

## IP Cameras

Cameras

Triggers

+ Add Trigger

Label	Event	Camera	Camera Operations	Actions
Lobby floor alarm	Partition - Lobby Floor Alarm Follow	Street cam North	3 images, 10 seconds clip	
Storage Tamper	Partition - Storage Rooms Tamper Follow	Street cam South	1 image	
Lobby Arming	Detector - Lobby South-East Arm Follow	Lobby main cam	5 images, 20 seconds clip	

Duplicate

**Figure 16 Camera Triggers List**

**NOTE** – You also have the options to edit , create a duplicate , or to delete the selected camera trigger.

**IMPORTANT** – No two camera triggers can be defined as identical. If a camera trigger is duplicated, the event, camera or both definitions must be changed.

# Troubleshooting

## Internet Configuration/UPnP Client Error

Not all routers support UPnP and in some routers UPnP is disabled by default. If you have tried configuring internet access automatically and get the message “unable to configure Internet Access”, “UPnP Client Error” or similar, it should be possible to set your IP cameras and router up manually.

### Step1: Login to your router

Use the router interface to identify the camera’s IP address. The Router Interface can be opened using any standard web browser.

1. Enter the local IP address of the router into the web browser’s address field. The Router Interface Login page is displayed.
2. Enter your username and password in the Login box that appears and click OK/Login.

---

**NOTE:** For more information on how to navigate your specific router please check the router’s User manual.

---

3. Navigate to the DHCP Client Table. The DHCP Client Table page is displayed.

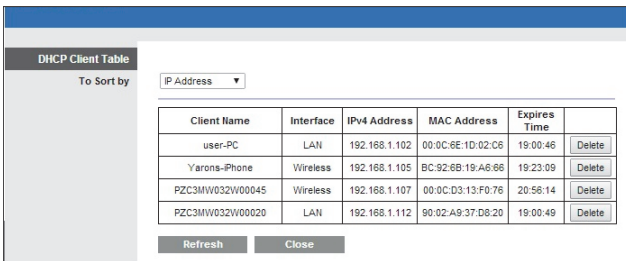

Client Name	Interface	IPv4 Address	MAC Address	Expires Time	
user-PC	LAN	192.168.1.102	00:0C:6E:1D:02:C6	19:00:46	Delete
Yarons-Phone	Wireless	192.168.1.105	BC:92:6B:19:A6:66	19:23:09	Delete
PZC3MW032W00045	Wireless	192.168.1.107	00:0C:D3:13:F0:76	20:56:14	Delete
PZC3MW032W00020	LAN	192.168.1.112	90:02:A9:37:D8:20	19:00:49	Delete

Figure 17 DHCP Client Table page

4. Make a note of the IP Address of the camera that you want to setup manually.

### Step 2: Camera Settings

Use the Camera Interface to setup the camera. The Camera Interface can also be opened using any standard web browser.

1. Enter the IP address and the web port of the camera, for example 192.168.010.168:37080 (default web port is 37080).

---

**NOTE –** When using more than one camera the default web port shouldn’t be the same

---



2. Once the Camera Interface Login page is displayed, enter the User and Password into the relevant fields and click Login.

NOTE – By Default the User and Password for camera login is “admin” and “\_AdmiN\_+ camera MAC address” (e.g. \_AdmiN\_AABBCCDDEEFF).

1. Once the Camera Interface page is displayed, select Setup > Network > UPnP. The UPnP Parameters page is displayed.

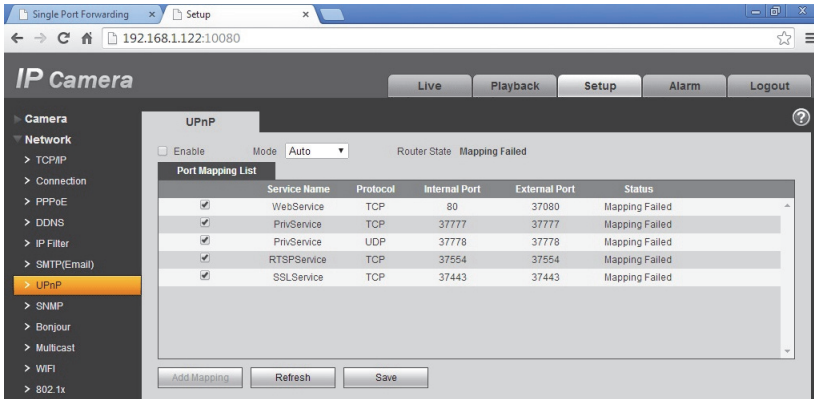

Figure 18 UPnP Parameters

2. Uncheck the UPnP Enable option and click Save.
3. Select TCP/IP. The TCP/IP Parameters page is displayed.

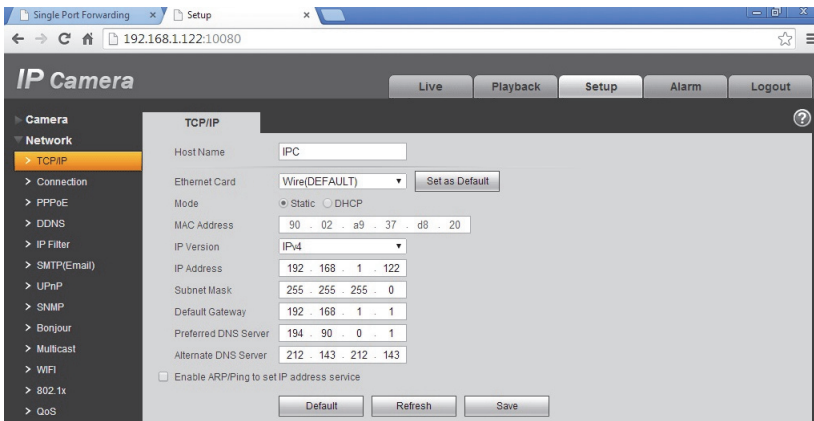

Figure 19 TCP/IP Parameters

4. Select the Static Mode option and enter the static IP address you want to set for the camera (in our example 192.168.1.122). Also set the subnet mask and Default gateway address (in our example 255.255.255.0 and 192.168.1.1).

---

**NOTE:** By default the TCP/IP settings should already be defined.

---

5. Click Save to save the changes.
6. Select Connection. The Connection Parameters page is displayed.

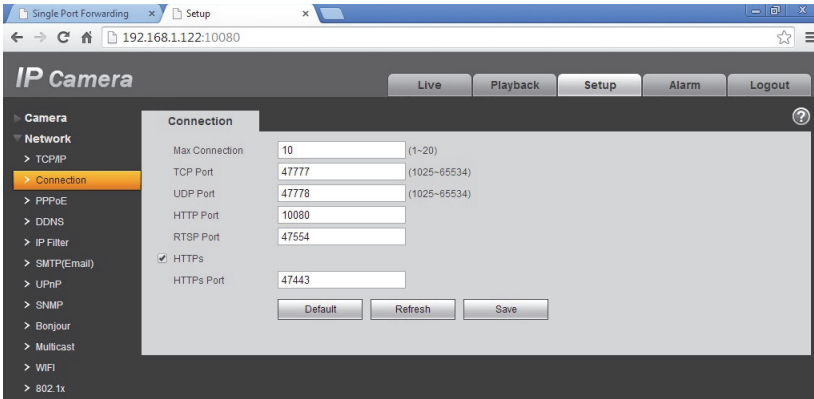

**Figure 20 Connection Parameters**

7. Set the following port connection parameters of the camera:

<b>TCP Port</b>	Set the TCP port you want to define for the camera (in our example 47777).
<b>UDP Port</b>	Set the UDP port (in our example 47778)
<b>HTTP Port</b>	The default port number is 80, and can be changed to any port range 1024 to 65535 (in our example 10080).
<b>RTSP Port:</b>	The default port number is 554 (in our example 47554).
<b>HTTPS Port</b>	The default port number is 443, and can be changed to any port range 1024 to 65535 (in our example 47443).

8. Click Save to save the changes.
9. Repeat the above steps for each camera using the relevant IP address and alternative port number for each.

### Step 3: Router Port Forwarding Settings

By default, the security features on many routers prevent access to the devices on your home/business network from the Internet. To open a port, you need to enable “port forwarding” on your router. Router administration screens can vary, but typically, you would do the following to open a port:

1. Return to the Router Interface page.

---

**NOTE:** For more information on how to navigate your specific router please check the routers User manual.

---

2. Navigate to the Advanced Setup > Port Forwarding/Port Triggering. The Port Forwarding page is displayed.

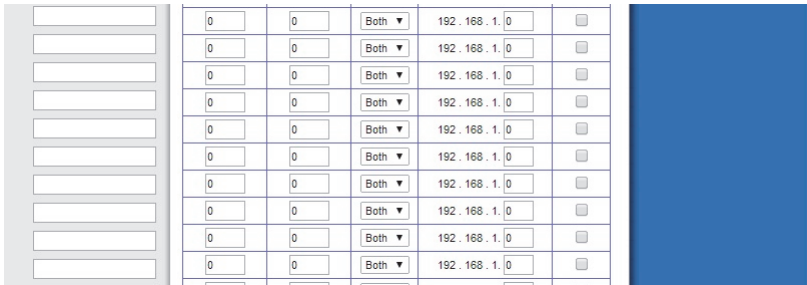

**Figure 21 Port Forwarding page (empty)**

**NOTE:** This is the section in the router where we will specify which local IP address belongs to which external port number. Make sure that “Port forwarding” is enabled for each IP address.

3. For the first camera enter the settings as shown in the screenshot below. Remember to use the same local IP address and external port numbers as was set in the camera settings in Step 2.

47777	47777	TCP ▼	192.168.1.122	<input checked="" type="checkbox"/>
47778	47778	UDP ▼	192.168.1.122	<input checked="" type="checkbox"/>
10080	10080	TCP ▼	192.168.1.122	<input checked="" type="checkbox"/>
47554	47554	TCP ▼	192.168.1.122	<input checked="" type="checkbox"/>
47443	47443	TCP ▼	192.168.1.122	<input checked="" type="checkbox"/>

**Figure 22 Port Forwarding page (populated)**

**NOTE:** For HTTP, RTSP and HTTPs Port settings use the TCP Protocol option.

4. Click Apply/Save Settings to save the changes.
5. Reboot the camera by unplugging and reconnecting the camera to the power supply.
6. Repeat the above steps for each camera using the same local IP address and external port numbers as was set in the camera settings.

# Product Specification

Parameter			
System	Main Processor	TI Davinci high performance DSP	
	OS	Embedded LINUX	
	System Resources	Support real-time network monitor, local record, and remote operation at the same time.	
	User Interface	Remote operation interface such as WEB, DSS, PSS.	
	System Status	Bit stream statistics, log, and software version.	
Video Parameter	Image Sensor	1/3-inch CMOS	
	Pixel	1280(H)*960(V)	
	Gain Control	Fixed/Auto	
	White Balance	Manual/Auto	
	BLC	On/Off	
	Exposure Mode	Manual/Auto PAL: It ranges from 1/3 to 1/10000. NTSC: It ranges from 1/4 to 1/10000.	
	Video Frame Rate	PAL: Main stream(1280*960@15fps) extra stream(352*288@15fps) Main stream(1280*720@25fps) extra stream(352*288@25fps) NTSC: Main stream(1280*960@15fps) extra stream(352*240@15fps) Main stream(1280*720@30fps) extra stream(352*240@30fps)	
	Video Bit Rate	H.264: 56Kbps-6144Kbps MJPEG is adjustable and bit rate is adjustable. Support customized setup.	
	Video Flip	Support mirror. Support flip function.	
	Snapshot	Max 1f/s snapshot. File extension name is JPEG.	
	Privacy Mask	Supports max 4 privacy mask zones	
	Video Setup	Support parameter setup such as bright, contrast.	
	Video Information	Channel title, time title, motion detect, camera masking.	
	Lens	3.6mm. Fixed focus. Angle of view: 70°(H) *51.5°(V)	
Lens Interface	M12. Lens is the default accessories		
Audio	Audio Bit Stream	Dual-way	
	Audio Input / Output	Built-in microphone and speaker	
	Audio Bit Rate	8kbps 16bit	
	Audio Compression Standard	G.711A/G.711Mu/PCM	
Video	N/A	N/A	
	Camera Masking	Sensitivity level ranges from 1 to 6. Each sensitivity level is the percentage of the privacy mask zone. Activation event: alarm device, audio/video storage, image snapshot, log, email SMTP function and etc.	
Alarm Port		1-channel input and 1-channel output (on-off)	
Record and Backu	Record Priority	Support remote record only	Manual>Video detect>Schedule
	SD Card Storage	Support Micro SD card	
	Storage Management	Support display network storage status	

Parameter		
Network	Wire Network	1-channel wire Ethernet port, 10/100 Base-T Ethernet
	Wireless Network	IEEE802.11a/b/g/n, built-in antenna
	Network Protocol	Standard HTTP, TCP/IP, ARP, IGMP, ICMP, RTSP, RTP,UDP, RTCP, SMTP, FTP, DHCP, DNS, DDNS UPNP, NTP, Bonjour, SNMP.
	Remote Operation IR light	Monitor, system setup, file download, log information, maintenance , upgrade and etc.
AUX Port	Compensation Light	White light (Max 1W) Auto turn on white light when an alarm is activated. The light can last until the alarm ends. Support compensation light brightness setup via the Web.
	N/A	N/A
	WPS	Click one button to enable WIFI connection
General Parameter	Power	DC 12V
	Power Consumption	6W MAX
	Working Temperature	-10 ~+50
	Working Humidify	10%~90%
	Dimensions(mm)	66.6*99.5*131.2
	Weight	229g ( Excluding box)
	Installation	Installation with the bracket.

# NOTES

# VUpoint Caméra IP Intérieure Cube



**Modèle: RVCM11H**

**FR**

**Guide d'Installation**

## Précautions d'Usage

Ces instructions sont destinées à faire en sorte que l'utilisateur puisse utiliser le produit correctement pour éviter le danger ou la perte matérielle.

### MISES EN GARDE:

- L'installation ou l'utilisation de ce produit sans respecter l'usage prévu tel que défini par le fournisseur et comme décrit dans les matériels pédagogiques peut entraîner des dommages, des blessures ou la mort.
- Assurez-vous que ce produit n'est pas accessible par les enfants et à ceux pour qui le fonctionnement du système n'est pas destiné.
- Toute installation et utilisation doivent être conformes aux codes de sécurité électrique locaux. L'alimentation doit être conforme à l'exigence de la SELV (Safety Extra Low Voltage) et la source d'alimentation 12 V DC limitée s'est vu attribuer l'IEC60950-1.
- Si le dispositif est relié en permanence à une source d'alimentation électrique, la connexion doit comporter un dispositif de déconnexion facile d'accès, tel qu'un disjoncteur. Ne pas connecter les deux sources d'alimentations à l'appareil en même temps, cela peut causer des dommages de l'appareil!
- Ne jamais tenter de réparer votre appareil vous-même, car cela peut entraîner des dommages, des blessures ou la mort - toujours contacter votre agent installateur/fournisseur pour la maintenance.

### AVERTISSEMENTS:

- Assurez-vous que la tension d'alimentation est correcte avant d'utiliser la caméra.
- Ne pas laisser tomber la caméra ou la soumettre à des chocs physiques.
- Ne touchez pas les modules capteurs avec les doigts. Si un nettoyage est nécessaire, utilisez un chiffon propre avec un peu d'éthanol et essuyez.
- Ne pas exposer l'objectif de la caméra à une forte lumière, comme le soleil ou une lampe à incandescence. La lumière forte peut causer des dommages mortels à la caméra.
- Le capteur peut être brûlé par un faisceau laser, si un appareil laser est utilisé, assurez-vous que la surface du capteur ne soit pas exposée au faisceau laser.
- Ne pas exposer la caméra à des températures extrêmes froides ou chaudes (la température de fonctionnement doit être comprise entre -10 ° C à +50 ° C).
- Pour éviter l'accumulation de chaleur, une bonne ventilation est nécessaire pour un bon environnement d'exploitation.
- Gardez la caméra loin de l'eau et de tout liquide.
- Pendant son transport, la caméra doit être emballée dans son emballage d'origine.

**NOTE:** Nous n'assumons aucune responsabilité pour tous les incendies ou les chocs électriques causés par une manipulation ou une mauvaise installation. Nous ne sommes pas responsables des problèmes causés par une modification non autorisée ou tentative de réparation.



## Introduction

RISCO Group présente VuPoint, une solution de vérification de la vidéo en direct révolutionnaire qui intègre de façon transparente les caméras IP au sein de nos systèmes de sécurité professionnels. Géré par RISCO Cloud, VuPoint offre un niveau de sécurité sans précédent en offrant la surveillance vidéo en direct aux stations de télésurveillance et aux utilisateurs commerciaux/résidentiels. La Caméra IP cube intérieure de RISCO est une partie importante de cette solution et est facilement contrôlé par les applications Smartphone et Web intuitives de RISCO.

## Caractéristiques

- Installation Simple 'Plug & Play'
- 1.3" Mégapixel
- Couleur HD
- Slot carte SD pour stockage local
- Wi-Fi
- LED IR (7-10m)

## Composants et Accessoires

Caméra IP RISCO et support de montage:



Chargeur électrique (non fourni avec la caméra) et sac d'accessoires d'installation:



Guide d'Installation:



## Exigences minimales du réseau Internet:

- 750 Kbps débit montant - upload (par caméra)
- 5 Mbps débit descendant – download

**RECOMMANDATION** - Vous pouvez installer plusieurs caméras avec l'exigence minimale recommandée (750 Kbps pour chaque caméra), mais notez que la visualisation de plusieurs caméras en parallèle peut réduire la vitesse de rafraîchissement et la qualité d'image.

## Composants Caméra IP et Dimensions

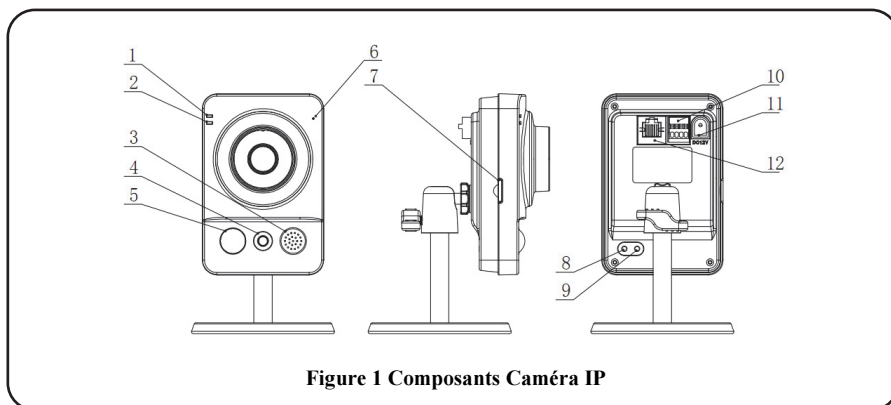
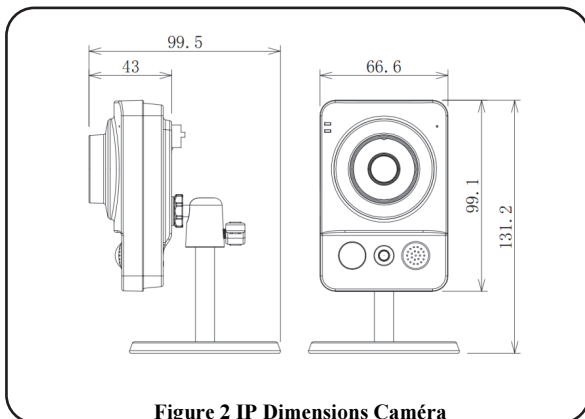

Figure 1 Composants Caméra IP

Indice	Nom Port	Indicateur	Connecteur	Description
1	Voyant d'alimentation	ALIM	/	<ul style="list-style-type: none"> <li>Lors du démarrage de la caméra – Allumée verte.</li> <li>Lorsque la caméra est en mise à jour - verte clignotante. - Intervalle de 0.5s.</li> <li>Lorsque la caméra est en alarme - verte clignotante. Intervalle de 0.2s.</li> </ul>
2	Voyant de réseau	RESEAU	/	<ul style="list-style-type: none"> <li>Connexion réseau filaire - allumée rouge.</li> <li>Connexion réseau sans fil – allumée verte.</li> </ul>
3	Haut-parleur	/	/	Signal audio de sortie (Cette fonction est optionnelle).
4	Lumière blanche	/	/	Peut s'activer sur détection de mouvement IRP, détection du mouvement corps humain, alarme externe.
5	N/A	N/A	N/A	N/A
6	Microphone	/	/	Recevoir directement le signal audio (Cette fonction est optionnelle).

Indice	Nom Port	Indicateur	Connecteur	Description
7	Carte Micro SD	Micro SD	Logement carte Micro SD	Carte SD stockage. Caractéristiques Micro SD: Type: class 4 Capacité: jusqu'à 64GB. <b>NOTE:</b> L'ajout de carte micro SD permet d'étendre la capacité d'enregistrement de clips vidéo. Les insertions/retraits de la carte micro SD, doivent être faites caméra éteinte..
8	Bouton Reset	Reset	/	Restaurer la configuration d'usine par défaut. Lorsque le système fonctionne normalement, maintenir appuyé le bouton RESET pendant au moins 5 secondes, le système peut restaurer la configuration d'usine par défaut.
9	Bouton WPS	WPS	Connexion sans fil rapide	Appuyez sur le bouton WPS du routeur et du périphérique respectivement pendant au moins 2 secondes. Habituellement, le dispositif se connecte au routeur en 1 minute. Veuillez noter s'il vous plaît que ceci ne s'applique qu'à un routeur sans fil avec fonctionnalité WPS.
10	N/A	N/A	N/A	N/A
11	Port Alimentation	DC12V	/	Entrée Alimentation 12V DC.
12	Port Réseau	LAN	Port Ethernet	Connecter un câble Ethernet standard.



**Figure 2 IP Dimensions Caméra**

## Installation Caméra IP

Après avoir lu les instructions d'installation et avant d'installer votre caméra IP, préparer un plan de montage de la caméra IP correspondant au site à protéger. L'emplacement correct de votre caméra IP est crucial pour une performance optimale de surveillance et de sécurité. Tout d'abord, déterminer les zones qui doivent être protégées et faire un plan des zones optimales pour l'installation de votre caméra IP.

**IMPORTANT!** – S'il vous plaît, veuillez noter l'adresse MAC située sur la boîte ou sur la couverture arrière de la caméra IP avant installation. Vous pourriez en avoir besoin au cours de la phase de connexion réseau.

Adresse MAC →

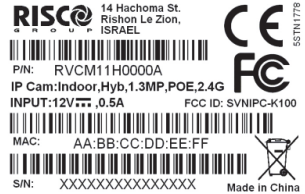

## Montage de la Caméra IP

Le support de caméra IP autorise deux options de montage; plafond et support mural (voir Figure 3 et Figure 4, ci-dessous).

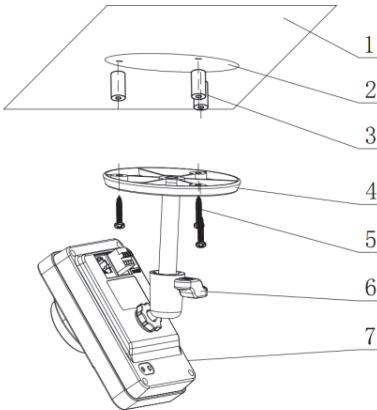

Figure 3 Montage Plafond

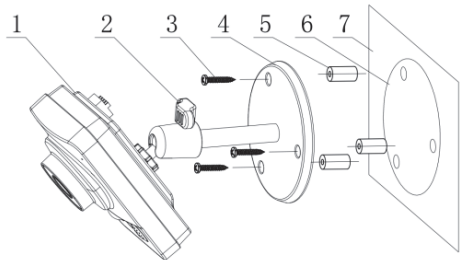

Figure 4 Montage Mural

**IMPORTANT-** S'il vous plaît assurez-vous que la surface de montage peut supporter au moins 3 fois le poids de la caméra et de son support.

Etape	Description
1	Placer le gabarit de positionnement d'installation sur la surface d'installation tel que plafond ou mur.
2	Faire des trous dans la surface d'installation selon le gabarit de positionnement d'installation.
3	Insérer les chevilles du sachet d'accessoires dans les trous que vous venez de percer.
4	Placez la base de la caméra IP sur les trous
5	Utilisez les vis du sachet d'accessoires pour fixer la caméra IP fermement.
6	Desserrer le bouton de réglage et régler la caméra IP à la position de la surveillance correcte en fonction de vos besoins réels.
7	Fixez le bouton de réglage pour fixer la caméra IP.

## Mise sous tension de la caméra IP

1. Branchez l'adaptateur d'alimentation électrique fourni au connecteur d'alimentation sur la caméra IP.
2. Branchez l'adaptateur d'alimentation à une prise électrique. Lorsque la caméra IP démarre, le témoin d'alimentation s'allume vert.

## Connexion de la Caméra IP au Réseau

La caméra IP supporte plusieurs options de connexion au réseau, y compris LAN et sans fil.

### Connexion au réseau local

Le raccordement de la caméra IP à un réseau en utilisant le LAN (Local Area Network) permet la connexion et les réglages avec les points d'accès compatibles, par exemple passerelle ou du routeur.

1. Branchez le câble de réseau entrant au port réseau sur la caméra IP.
2. Attendez quelques minutes pendant que la caméra IP se connecte automatiquement au RISCO Cloud. L'indicateur de réseau ROUGE indique que votre caméra IP est maintenant prête pour la définition de ses paramètres (Reportez-vous à Définition des paramètres de caméras IP).

## Connexion à un Réseau Sans fil utilisant WPS

Le Raccordement de la caméra IP à un réseau sans fil en utilisant le WPS (Configuration Wi-Fi Protected) exige que le routeur et le système d'exploitation prennent en charge la fonctionnalité WPS.

---

**NOTE** – Certains routeurs disposent d'un bouton virtuel dans leur logiciel de gestion. (Reportez-vous à la documentation du routeur pour plus de détails sur l'utilisation de ses fonctions WPS).

---

1. Une fois le cordon d'alimentation branché, attendre 5 minute pour que la caméra démarre.
2. Appuyez et maintenez enfoncé le bouton WPS sur la caméra IP et le bouton WPS sur le routeur respectivement pendant 2 secondes. L'indicateur de réseau voyant vert indique que votre caméra IP est maintenant prête pour la définition de ses paramètres (Reportez-vous à Définition des paramètres de caméras IP).

## Connexion à un Réseau Sans fil utilisant le Cloud RISCO

Le raccordement de la caméra IP à un réseau sans fil en utilisant le RISCO Cloud (RISCO Application Server) nécessite que vous connectiez physiquement la première fois la caméra IP au routeur, puis, à partir de la RISCO Cloud Application Installateur, définir les paramètres de la caméra IP et établir une connexion sans fil. Une fois la connexion sans fil établie, la caméra IP peut être déconnecté du routeur et installée.

1. Branchez le câble de réseau entrant au port réseau sur la caméra IP.
2. Attendez quelques minutes que la caméra IP se connecte automatiquement au RISCO Cloud (RISCO Application Server). L'indicateur réseau ROUGE indique que votre caméra IP est maintenant prêt pour la définition des paramètres de la caméra (Reportez-vous à Définition des paramètres de caméras IP).
3. Une fois la connexion sans fil établie, débrancher la caméra IP du routeur et l'installer n'importe où dans la zone surveillée.

---

### **NOTES:**

1. Pour connecter la caméra IP à RISCO Cloud via UPnP, le routeur doit être certifié UPnP. Si votre routeur n'est pas certifié UPnP, nous recommandons de ne pas utiliser l'UPnP et d'ouvrir les ports de la caméra manuellement dans le routeur (Voir la section Dépannage pour plus d'informations).
  2. La caméra IP ne peut pas être connectée à plus d'un routeur à la fois.
-

# Caméras IP et Application Installateur RISCO Cloud

L'application Installateur RISCO Cloud fournit une interface pour contrôler votre centrale à partir d'un PC local ou à distance via le Web. Cela vous permet d'ajouter des caméras IP et de définir la caméra et les paramètres des événements d'alarme de déclenchement.

**IMPORTANT** – La centrale doit d'abord être définie dans RISCO Cloud pour accepter des caméras IP et définir les paramètres de la caméra (Reportez-vous au manuel de l'application Installateur RISCO Cloud)

## Définition des paramètres de caméras IP

Une fois que vous avez connecté la caméra IP sur le réseau (Reportez-vous à, Raccordement de la caméra IP au réseau) vous pouvez définir les paramètres de la caméra.

### Pour définir les paramètres de la caméra IP:

1. Connectez-vous à l'application Administration Installateur en utilisant l'adresse de la page Web fournie par votre fournisseur de services et saisissez votre nom d'utilisateur et mot de passe.

**NOTA** – Il est recommandé d'utiliser Google Chrome ou Mozilla Firefox pour se connecter à l'application d'administration installateur.

2. Sélectionnez le lien Liste des Centrales. La page Liste des centrales s'affiche.

CP Login ID	Web Login ID	First Name	Last Name	Cell Phone	Provider (1st)	Account	Last Connected Time	Online?
TCONNECT203							7/17/2012 9:39:48 AM	No
22400000123							4/19/2012 5:34:47 PM	No
22400048768								Never
22400036472							5/14/2012 3:26:34 PM	No
22400000014							4/25/2012 9:00:11 AM	No
22400065764							5/21/2012 3:25:56 PM	No
22400000010							4/30/2012 1:11:16 PM	No
22400066013							5/2/2012 4:55:14 PM	No
22400000012							9/27/2012 1:01:38 PM	No
22400065725							9/19/2012 12:27:16 PM	No

Figure 5 Page Liste des centrales

3. Dans la page Liste des Centrale, sélectionnez la centrale que vous souhaitez consulter. La page des centrales mises à jour est affichée.

Figure 6 Page Centrale Mise à jour

4. Cliquez sur le lien caméras réseau dans la colonne de gauche, la page de la liste des caméras IP s'affiche.

Figure 7 Liste Caméras IP

5. Cliquez sur Ajouter caméra, la boîte de dialogue d'ajout de caméra s'affiche.

Figure 8 Ajout Caméra

6. Définir les champs suivants dans la boîte de dialogue Ajout Caméra.

Champ	Description
Etiquette	Entrez un nom pour la caméra
Partitions	Sélectionnez la(les) partition(s) dans la liste des partitions définies
Type	Choisissez le type de caméra RISCO (pour le paramètres du type ONVIF ou camera générique, Reportez-vous au manuel de l'application Installateur RISCO Cloud)



Champ	Description
Adresse MAC	Entrez l'adresse MAC comme indiqué sur la boîte ou sur la couverture arrière de la caméra IP. L'adresse MAC (media access control address) est l'identifiant unique attribué à la caméra IP pour les communications sur le réseau physique. <b>NOTE:</b> L'adresse MAC est sensible à la casse et doit être saisie exactement comme elle est indiquée sur la boîte ou sur le capot arrière de la caméra IP, par exemple, AA: BB: CC: DD: EE: FF

7. Cliquer sur Ajouter. Si le message "La caméra a été identifiée avec succès" s'affiche passer à l'étape 8.

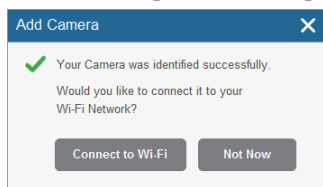
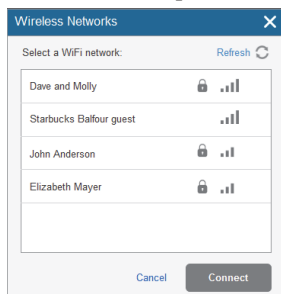

**Figure 9 Message "La caméra a été identifiée avec succès"**

8. Si "Impossible de configurer l'accès à Internet", "Erreur UPnP Client" ou un message similaire s'affiche, reportez-vous à la section Dépannage.

**NOTE** – Ce message n'est pertinent que pour les caméras IP qui sont physiquement connectés au réseau LAN via le routeur.

9. Sélectionnez l'une des options suivantes:
10. **Connecter au Wi-Fi** – pour établir une connexion réseau sans fil (passez à l'étape 9 pour connecter la caméra IP au réseau sans fil).  
**Pas Maintenant** – pour établir une connexion réseau LAN (sauter la connexion réseau sans fil étapes 9, 10 et 11 et connecter la caméra IP au réseau LAN).
11. Si vous avez sélectionné l'option "Connecter au Wi-Fi", une liste des réseaux sans fil disponibles s'affiche.



**Figure 10 Liste des réseaux sans fil disponibles**

12. Sélectionnez un réseau sans fil dans la liste disponible, puis cliquez sur Connecter.

---

**NOTE** – Si votre réseau est protégé par mot, un mot de passe doit être entré dans l'écran de mot de passe affiché.

---

13. Cliquez sur OK pour établir la connexion sans fil (Reportez-vous à **Connexion à un Réseau Sans fil utilisant le Cloud RISCO**).

---

**IMPORTANT** – Une fois la connexion sans fil a été établie, ne pas oublier de débrancher la câble Ethernet de la caméra IP du routeur.

---

14. Une fois la "caméra est prête à l'emploi» s'affiche, cliquez sur OK. La caméra IP définie est affichée dans la page des caméras IP.

## IP Cameras

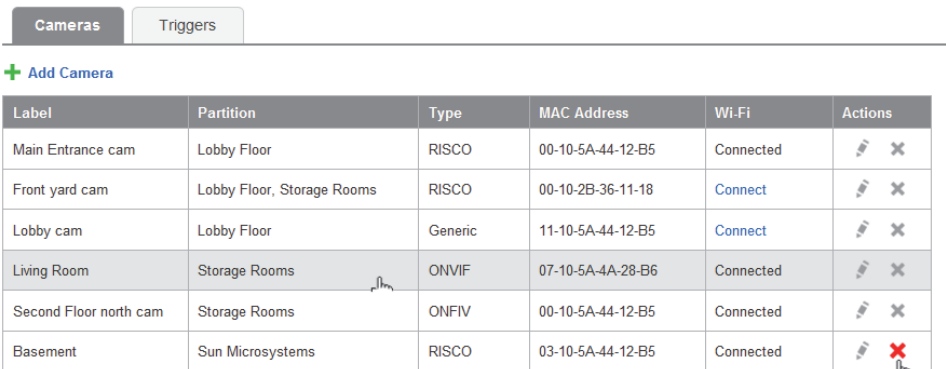

Label	Partition	Type	MAC Address	Wi-Fi	Actions
Main Entrance cam	Lobby Floor	RISCO	00-10-5A-44-12-B5	Connected	
Front yard cam	Lobby Floor, Storage Rooms	RISCO	00-10-2B-36-11-18	Connect	
Lobby cam	Lobby Floor	Generic	11-10-5A-44-12-B5	Connect	
Living Room	Storage Rooms	ONVIF	07-10-5A-4A-28-B6	Connected	
Second Floor north cam	Storage Rooms	ONVIF	00-10-5A-44-12-B5	Connected	
Basement	Sun Microsystems	RISCO	03-10-5A-44-12-B5	Connected	

**Figure 11** Liste Caméras IP

---

**NOTE** – Vous avez également la possibilité de modifier ou supprimer la caméra IP sélectionnée.

---

## Définition des paramètres de déclenchement de la caméra

Tout événement dans la liste suivante peut être défini pour déclencher une alarme.

Evènements Partition			
Alarme Incendie	Alarme Panique	Alarme Médical	Alarme
Armement Total	Armement Partiel	Désarmement	Agression
Sabotage	Alarme 24 HR-X	Alarme Inondation	Alarme Gaz
Alarme Environ.	Alarm Inactivité	Alarme Sortie	Température basse
Evènements Détecteur			
Alarme	Zone Exclue	Zone Inclue	Zone Sabotage

### Pour définir les paramètres de déclenchement de la caméra:

1. Dans la page de configuration Caméras, cliquez sur l'onglet Déclencheurs, la page de la liste des déclencheurs de caméra s'affiche.

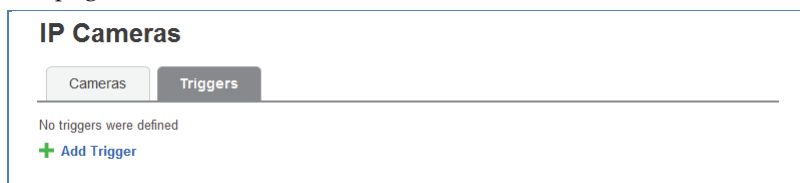

Figure 12 Liste des déclencheurs Caméra

2. Cliquez sur Ajouter déclencheur; la boîte de dialogue Ajouter déclencheur apparaît.

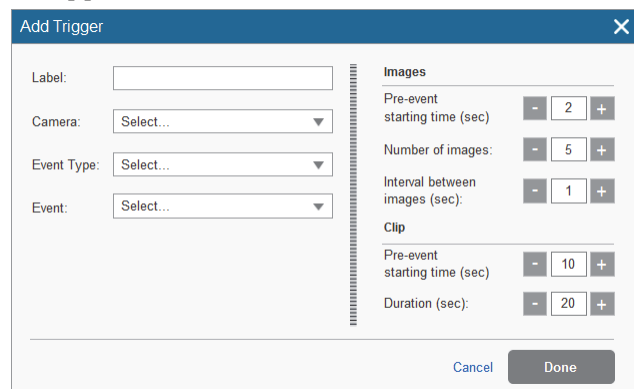

Figure 13 Ajout déclencheur

3. Définir les champs suivants dans la boîte de dialogue d'ajout de déclencheur:

Champ	Description	Type d'événements
<b>Etiquette</b>	Entrez un nom pour le déclencheur de caméra	Événements Partition et Détecteur
<b>Caméra</b>	Choisir une caméra dans la liste	Événements Partition et Détecteur
<b>Type Événement</b>	Choisissez un type d'événements dans la liste.	Événements Partition et Détecteur
<b>Événement</b>	Choisissez un type d'événements dans la liste par ex. alarme, contrainte, etc.	Événements Partition et Détecteur

Les champs supplémentaires sont affichés dans la boîte de dialogue Ajouter déclenchement, selon le type d'événement que vous avez sélectionné (voir les exemples ci-dessous pour les types d'événements partition et détecteurs).

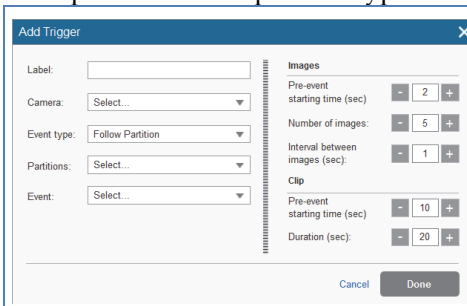

Figure 14 Ajouter un déclencheur d'événement Partition

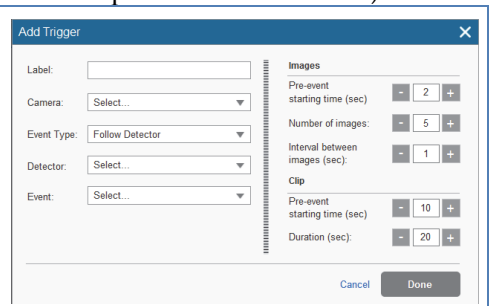

Figure 15 Ajouter d'un déclencheur d'événement détecteur

4. Définir les champs suivants dans la boîte de dialogue Ajout Déclencheur selon le type d'événement que vous avez sélectionné.

Champ	Description	Type Événement
<b>Partition(s)</b>	Sélectionnez la(les) partition(s) dans la liste. <b>NOTE</b> – Seules les partitions associées à la caméra sont affichées.	Événements de partition seulement
<b>Détecteurs</b>	Sélectionnez le détecteur dans la liste	Événements de détecteur seulement
<b>Événements</b>	Sélectionnez l'événement dans la liste	Événements de détecteur et partitions

5. Définir les définitions suivantes pour l'image (fixe) et le clip (vidéo) :

Champ	Description
<b>Images (fixes)</b>	<b>Durée de préalarme (sec)</b> – temps, avant l'événement réel survenu, pour commencer à afficher des images fixes. <b>Nombre d'images</b> – nombre d'images fixes à afficher. <b>Intervalle entre images (sec)</b> – temps nécessaire entre chaque image fixe.
<b>Clips (vidéo)</b>	<b>Durée de préalarme (sec)</b> – temps, avant l'événement réel survenu, pour commencer l'affichage vidéo. <b>Durée (sec)</b> – durée totale de la séquence vidéo <b>NOTE</b> - Ces champs sont actuellement verrouillés et les paramètres par défaut ne peuvent pas être modifiés.

6. Une fois terminé, cliquez sur Terminer. Le déclencheur de la caméra défini est affiché dans la page de la liste des déclencheurs de caméra.

## IP Cameras

Cameras
Triggers

+ Add Trigger

Label	Event	Camera	Camera Operations	Actions
Lobby floor alarm	Partition - Lobby Floor Alarm Follow	Street cam North	3 images, 10 seconds clip	
Storage Tamper	Partition - Storage Rooms Tamper Follow	Street cam South	1 image	
Lobby Arming	Detector - Lobby South-East Arm Follow	Lobby main cam	5 images, 20 seconds clip	

Duplicate

Figure 16 Liste des déclencheurs de caméra

**NOTE** – Vous avez également la possibilité de modifier , créer un double , ou supprimer le déclencheur de caméra sélectionné.

**IMPORTANT** – Deux déclencheurs de la caméra ne peuvent être définies comme identiques. Si un déclencheur de caméra est dupliqué, l'événement, la caméra ou les deux définitions doivent être changés.

## Configuration Internet / Erreur Client UPnP

Tous les routeurs ne supportent pas l'UPnP et pour certains routeurs l'UPnP est désactivé par défaut. Si vous avez essayé de configurer l'accès automatique à Internet et reçu un message "Impossible de configurer l'accès Internet", "Erreur Client UPnP" ou similaire, il est alors possible de configurer vos caméras IP et votre routeur manuellement.

### Étape 1: Connectez-vous à votre routeur

Utilisez l'interface du routeur pour identifier l'adresse IP de la caméra. L'interface du routeur peut être ouverte en utilisant n'importe quel navigateur Web standard.

1. Saisissez l'adresse IP locale du routeur dans le champ d'adresse du navigateur Web. La page de l'interface de connexion du routeur s'affiche.
2. Entrez votre nom d'utilisateur et mot de passe dans la boîte de connexion qui s'affiche et cliquez sur OK/Connexion.

**NOTE:** Pour plus d'informations sur la façon spécifique de naviguer dans votre routeur, s'il vous plaît veuillez vérifier le manuel utilisateur du routeur.

3. Accédez à la table des clients DHCP. La page de la table des clients DHCP s'affiche.

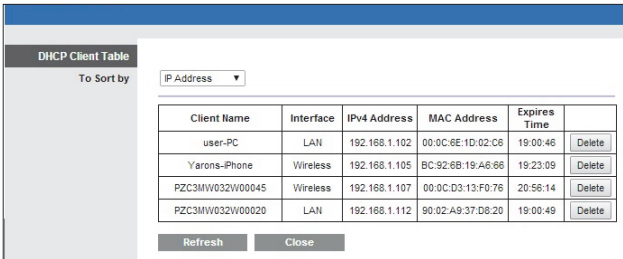

Client Name	Interface	IPv4 Address	MAC Address	Expires Time	
user-PC	LAN	192.168.1.102	00:0C:6E:1D:02:C6	19:00:46	Delete
Yarons-iPhone	Wireless	192.168.1.105	BC:92:6B:19:A6:66	19:23:09	Delete
PZC3MW032W00045	Wireless	192.168.1.107	00:0C:D3:13:F0:76	20:56:14	Delete
PZC3MW032W00020	LAN	192.168.1.112	90:02:A9:37:D8:20	19:00:49	Delete

Figure 17 Page Table Client DHCP

4. Prenez note de l'adresse IP de la caméra que vous souhaitez configurer manuellement.

### Etape 2: Configuration Caméra

Utilisez l'interface de la caméra pour configurer la caméra. L'interface de la caméra peut également être ouverte à l'aide de n'importe quel navigateur Web standard.

1. Saisissez l'adresse IP et le port Web de la caméra, par exemple 192.168.010.168:37080 (le port Web par défaut est 37080).

**NOTE** – Lorsque vous utilisez plusieurs caméras, le port Web par défaut ne doit pas être le même.

2. Une fois que la page d'interface de connexion de la caméra s'affiche, entrez les noms d'utilisateur et mot de passe dans les champs appropriés et cliquez sur Connexion.

**NOTE** – Par défaut, l'utilisateur et mot de passe pour la caméra connexion sont "admin" et "\_AdmiN\_+Adresse MAC caméra" (ex. \_AdmiN\_AABBCCDDEEFF).

3. Une fois la page de l'interface de la caméra affichée, sélectionnez Configuration> Réseau> UPnP. La page des Paramètres UPnP s'affiche.

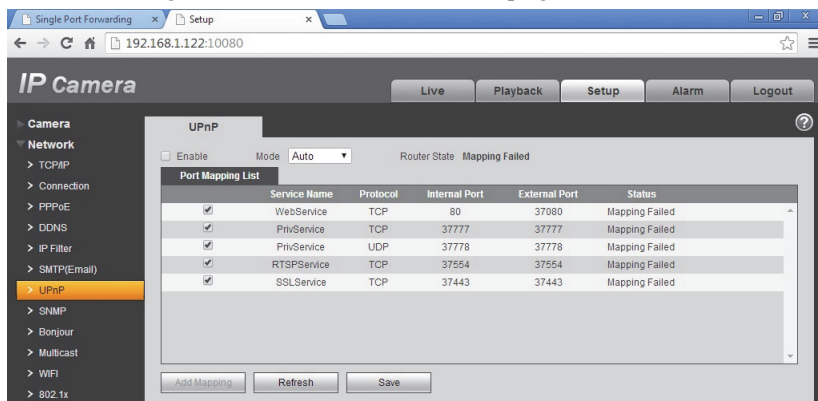

Figure 18 Paramètres UPnP

4. Décochez l'option UPnP 'Enable' et cliquez sur Save.
5. Sélectionner TCP/IP. La page des paramètres TCP/IP s'affiche.

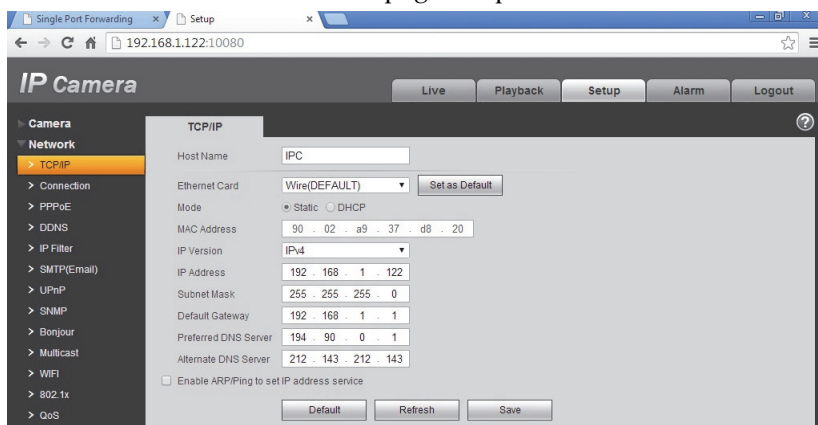
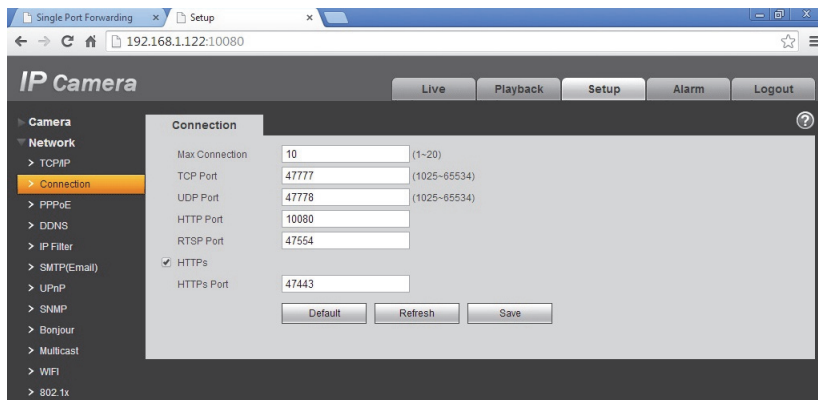

Figure 19 Paramètres TCP/IP

- Sélectionnez l'option de mode 'Static' et entrez l'adresse IP statique que vous souhaitez définir pour la caméra (dans notre exemple 192.168.1.122). Définir également le masque de sous-réseau et l'adresse de la passerelle par défaut (dans notre exemple 255.255.255.0 et 192.168.1.1).

**NOTE:** Par défaut, les paramètres TCP / IP doivent déjà être définies.

- Cliquez sur 'Save' pour enregistrer les modifications.
- Sélectionner Connection. La page Paramètres de connexion s'affiche.



**Figure 20 Paramètres Connexion**

- Définissez les paramètres des ports de connexion suivants de la caméra:

<b>TCP Port</b>	Réglez le port TCP que vous souhaitez définir pour la caméra (dans notre exemple 47777).
<b>UDP Port</b>	Réglez le port UDP (dans notre exemple 47778)
<b>HTTP Port</b>	Le numéro de port par défaut est 80, il peut être modifié à n'importe quelle valeur comprise entre 1024 à 65535 (dans notre exemple 10080).
<b>RTSP Port:</b>	Le numéro de port par défaut est 554 (dans notre exemple 47554).
<b>HTTPS Port</b>	Le numéro de port par défaut est 443, il peut être modifié à n'importe quelle valeur comprise entre 1024 à 65535 (dans notre exemple 47443).

- Cliquez sur 'Save' pour enregistrer les modifications.



11. Répétez les étapes précédentes pour chaque caméra en utilisant l'adresse IP appropriée et le numéro de port alternatif pour chacune.

### Etape 3: Configuration de la redirection des ports du Routeur

Par défaut, les fonctions de sécurité sur de nombreux routeurs empêchent l'accès à Internet aux périphériques de votre réseau domestique/d'entreprise. Pour ouvrir un port, vous devez activer la "redirection de port" sur votre routeur. Les écrans d'administration du routeur peuvent différer, mais en général, vous devez procéder comme suit pour ouvrir un port:

1. Retourner à la page de l'interface du routeur.

**NOTE:** Pour plus d'informations sur la façon spécifique de naviguer dans votre routeur, s'il vous plaît veuillez vérifier le manuel utilisateur du routeur.

2. Accédez à la configuration avancée > Redirection/Déclencheur Port. La page Redirection Port s'affiche.

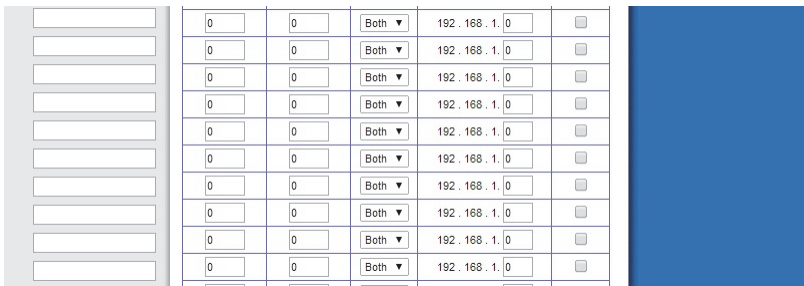

**Figure 21 Page Redirection Port (vide)**

**NOTE:** Dans cette section du routeur nous allons spécifier l'adresse IP locale associé au numéro de port externe. Assurez-vous que la "redirection de port" est activée pour chaque adresse IP.

3. Pour la première caméra entrez les paramètres indiqués dans la capture d'écran ci-dessous. N'oubliez pas d'utiliser les mêmes adresses IP locale et numéro port externe précédemment définis dans les paramètres de la caméra à l'étape 2.

<input type="text" value="47777"/>	<input type="text" value="47777"/>	TCP ▾	<input type="text" value="192.168.1.122"/>	<input checked="" type="checkbox"/>
<input type="text" value="47778"/>	<input type="text" value="47778"/>	UDP ▾	<input type="text" value="192.168.1.122"/>	<input checked="" type="checkbox"/>
<input type="text" value="10080"/>	<input type="text" value="10080"/>	TCP ▾	<input type="text" value="192.168.1.122"/>	<input checked="" type="checkbox"/>
<input type="text" value="47554"/>	<input type="text" value="47554"/>	TCP ▾	<input type="text" value="192.168.1.122"/>	<input checked="" type="checkbox"/>
<input type="text" value="47443"/>	<input type="text" value="47443"/>	TCP ▾	<input type="text" value="192.168.1.122"/>	<input checked="" type="checkbox"/>

**Figure 22 Page Redirection Port (remplie)**

**NOTE:** Pour HTTP, RTSP et HTTPS les paramètres du port utilisent l'option Protocole TCP.

4. Cliquez sur Appliquer/Enregistrer les paramètres pour enregistrer les modifications.
5. Redémarrez la caméra en débranchant et en rebranchant son alimentation.
6. Répétez les étapes précédentes pour chaque caméra en utilisant l'adresse IP locale et les numéros de port externes précédemment défini dans les paramètres de la caméra.

## Spécifications Produit

Paramètres		
Système	Processeur principal	TI Davinci DSP haute performance
	OS	LINUX embarqué
	Ressources Système	Support visualisation réseau en temps réel, enregistrement local, et exploitation distante simultanés.
	Interface Utilisateur	Interface de gestion à distance tels que WEB, DSS, PSS.
	Etat Système	Statistiques de débits, historique, et version du logiciel.
Paramètre Vidéos	Capteur Image	1/3-inch CMOS
	Pixel	1280(H)*960(V)
	Contrôle de Gain	Fixe/Auto
	Balance des blancs	Manuelle/Auto
	BLC	Marche/Arrêt
	Mode Exposition	Manuelle/Auto
	Flux Vidéo	PAL: Flux Principal (1280*960@15fps) Flux supplémentaire (352*288@15fps), Flux Principal (1280*720@25fps) Flux supplémentaire (352*288@25fps) NTSC: Flux Principal (1280*960@15fps) Flux supplémentaire (352*240@15fps) Flux Principal (1280*720@30fps) Flux supplémentaire (352*240@30fps)
	Débit Vidéo	H.264: 56Kbps-6144Kbps MJPEG est réglable et le débit binaire est réglable. Supporte une configuration personnalisée.
	Flip Vidéo	Supporte miroir. Supporte la fonction de bascule.
	Capture instantanée	Max 1f/s Capture. Extension du nom de fichier est JPEG.
	Masque confidentialité	Prise en charge de 4 zones de masque de la vie privée max
	Config. Vidéo	Support de configuration des paramètres tels que lumière, contraste.
	Information Vidéo	Titre canal, titre horaire, détection de mouvement, masquage caméra.
Objectif	3.6mm. focus Fixe. Angle de vue: 70°(H) *51.5°(V)	

Paramètres			
	Interface objectif	M12. Objectif, accessoire par défaut	
Audio	Flux Audio	Bidirectionnel	
	Entrée/Sortie Audio	Microphone et haut-parleur intégrés	
	Débit Audio	8kbps 16bit	
	Compression Audio Standard	G.711A/G.711Mu/PCM	
vidéo	Masquage Caméra	Niveau de sensibilité de 1 à 6. Chaque niveau de sensibilité est le pourcentage de la zone de masque de confidentialité. Evènement d'activation: Alarme accessoire, stockage audio / vidéo, capture d'images, historique, fonction messagerie SMTP, etc.	
Port Alarme		1 canal Entrée et 1 canal sortie (on-off)	
Enreg. et Backup	Priorité Enregistrement	Support enregistrement distant seul.	Manuel>Déteçt. Vidéo >Planification
	Stockage sur SD Card	Support carte micro SD	
	Gestion Stockage	Supporte l'état des unités de stockage en réseau	
Réseau	Réseau filaire	1-canal port filaire Ethernet, 10/100 Base-T Ethernet	
	Réseau Sans-Fil	IEEE802.11a/b/g/n, Antenne intégrée	
	Protocole Réseau	Standard HTTP, TCP/IP, ARP, IGMP, ICMP, RTSP, RTP, UDP, RTCP, SMTP, FTP, DHCP, DNS, DDNS, UPNP, NTP, Bonjour, SNMP.	
	Commande distante Lumière IR	Monitoring, configuration système, transfert fichier, informations journal, maintenance, mise à jour, etc.	
Port AUX	Compensation Lumière	Lumière blanche (Max 1W) Allumage Auto de la lumière blanche lorsque l'alarme est activée. Peut s'activer jusqu'à la fin de l'alarme. Configuration de la luminosité de la lumière de compensation via le Web.	
	WPS	Cliquez sur un bouton pour activer la connexion WIFI	
	Alimentation	DC 12V	
Paramètres Généraux	Consommation	6W MAX	
	Température de fonctionnement	-10°C~+°~+50°C	
	Humidité de fonctionnement	10%~90%	
	Dimensions (mm)	66.6*99.5*131.2	
	Poids	229g (Exclu boîte)	
	Installation	Installation avec support.	

## NOTES

# VUpoint Telecamera IP da interno Cube



**Modello: RVCM11H**



**Manuale di Installazione**

## Precauzioni sulla sicurezza

Queste istruzioni hanno lo scopo di garantire che l'utente utilizzi il prodotto in modo corretto per evitare pericoli o danni a terzi.

### **AVVERTENZE:**

- L'installazione o l'utilizzo di questo prodotto non in conformità con la destinazione d'uso, come definito dal fornitore e come descritto nel seguente manuale, può provocare danni, lesioni o morte. Assicurarsi che questo prodotto non sia accessibile a bambini o a persone a cui il sistema non è destinato.
- L'installazione e il collegamento devono essere conformi alle norme di sicurezza del proprio paese ed effettuate da persone esperte. L'alimentatore utilizzato per il suddetto prodotto deve avere tensione di uscita 12 Vdc e deve essere conforme al requisito SELV (Safety Extra Low Voltage) (IEC60950-1).
- Se il dispositivo è collegato in modo permanente ad una fonte di alimentazione elettrica, allora la connessione deve includere un dispositivo di disconnessione facilmente accessibile, ad esempio un magnetotermico.
- Non tentare mai di riparare il dispositivo da soli in quanto ciò potrebbe causare danni, lesioni o morte. Contattare sempre il vostro installatore/fornitore.

### **PRECAUZIONI:**

- Assicurarsi che la tensione di alimentazione sia corretta prima di utilizzare la telecamera.
- Non far cadere la telecamera o sottoporla a urti.
- Non toccare il modulo sensore con le dita. Se è necessario pulire l'apparato, utilizzando un panno pulito e strofinando delicatamente.
- Non puntare l'obiettivo della telecamera direttamente verso fonti di luce come il sole o una lampada ad incandescenza. La luce forte può provocare danni irreparabili alla telecamera.
- Il sensore della telecamera può essere bruciato da un raggio laser. Quando viene utilizzata qualsiasi apparecchiatura laser assicurarsi che la superficie del sensore non sia esposta allo stesso.
- Non posizionare la telecamera in condizioni ambientali estreme (la temperatura di esercizio deve essere compresa tra  $-10^{\circ}\text{C}$  ~  $+50^{\circ}\text{C}$ ).
- Per evitare surriscaldamenti il luogo di installazione deve avere una ventilazione adeguata.
- Tenere la telecamera lontano da acqua e da altri liquidi.
- Durante il trasporto, la telecamera deve essere contenuta nel suo imballo originale.

**NOTE:** RISCO non si assume la responsabilità per eventuali incendi o scosse elettriche causate da un uso improprio o da un'installazione non corretta dell'apparato. RISCO non è altresì responsabile per eventuali problemi causati da modifiche non autorizzate o tentativi di riparazione effettuate sul prodotto.

## Introduzione

RISCO Group presenta VuPoint, una soluzione rivoluzionaria di verifica video live che integra perfettamente le Telecamere IP nei sistemi di sicurezza professionali RISCO. Utilizzando il Cloud di RISCO (RISCO Application Server), VuPoint fornisce un livello di sicurezza e di monitoraggio video in tempo reale per le Vigilanze e per gli utenti finali senza precedenti. La telecamera IP "CUBE" di RISCO è parte integrante di questa soluzione ed è facilmente controllabile attraverso applicazioni smartphone o attraverso intuitive pagine Web.

## Caratteristiche

- Installazione semplificata Plug & Play
- 1.3" Megapixel
- Colore HD
- Day/Night
- LED IR (Portata 7-10 metri)

## Componenti e Accessori

Telecamera Risco e Staffa di Montaggio



Componenti e Accessori



Manuale di Installazione



## Requisiti della connessione Internet:

- Velocità di upload 750 Kbps (per ogni camera)
- Velocità di download 5 Mbps

**IMPORTANTE:** E' possibile installare più di una telecamera se si dispone di una connessione ad Internet con velocità di upload pari a 750 Kbps o leggermente inferiore. In questo caso la visualizzazione contemporanea di più telecamere potrebbe risultare rallentata e perdere in qualità dell'immagine. La visualizzazione contemporanea di più telecamere avviene solo quando da due o più APP viene richiesto il flusso video live (streaming) della stessa o telecamere diverse.

## Telecamera IP - Componenti e Dimensioni



Figura 1 Telecamera IP - Componenti

Nr	Nome	Funzione	Connettore	Descrizione
1	Indicatore Alimentazione	ALIMENTAZIONE	/	<ul style="list-style-type: none"> <li>Quando la telecamera si avvia il LED verde si accende.</li> <li>Quando la telecamera è in aggiornamento il LED verde lampeggia ad intervalli di 0.5s.</li> <li>Quando la telecamera è in allarme il LED verde lampeggia ad intervalli di 0.2s.</li> </ul>
2	Indicatore presenza Rete	RETE DATI	/	<ul style="list-style-type: none"> <li>Connessione di rete cablata – LED acceso di colore rosso.</li> <li>Connessione di rete Wireless - LED acceso di colore verde.</li> </ul>
3	Altoparlante	/	/	Segnale Audio in uscita (Opzionale).
4	Illuminatore IR	LED Rosso	/	Il LED si attiva autonomamente quando la luminosità è scarsa.
5	Non/Usato	Non/Usato	Non/Usato	Non/Usato
6	Microfono	/	/	Segnale audio in ingresso (Opzionale).



Nr	Nome	Funzione	Connettore	Descrizione
7	Micro SD card	Micro SD	Slot per scheda Micro SD	Scheda di memoria SD non fornita. Caratteristiche: TIPO : Classe 4 Memoria : Minimo 4Gb fino a 64Gb Quando si inserisce/sostituisce la scheda Micro SD, <b><i>la telecamera deve essere spenta.</i></b>
8	Tasto Reset	Reset	/	Ripristina le impostazioni predefinite in fabbrica. Quando la telecamera funziona normalmente, premere il tasto RESET per almeno 5 secondi, il sistema ripristina la configurazione di fabbrica.
9	Tasto WPS	WPS	Connessione Wireless veloce	Premere rispettivamente il pulsante WPS del router e del dispositivo per almeno 2 secondi. Il dispositivo si connette al router entro 1 minuto. <b>Importante:</b> la telecamera si connette solo a router wireless che hanno la funzionalità WPS.
10	Non/Usato	Non/Usato	Non/Usato	Non/Usato
11	Ingresso Alimentazione	DC12V	/	Ingresso 12V DC.
12	Ingresso Network	LAN	Porta Ethernet	Collegare ad una presa standard ethernet.

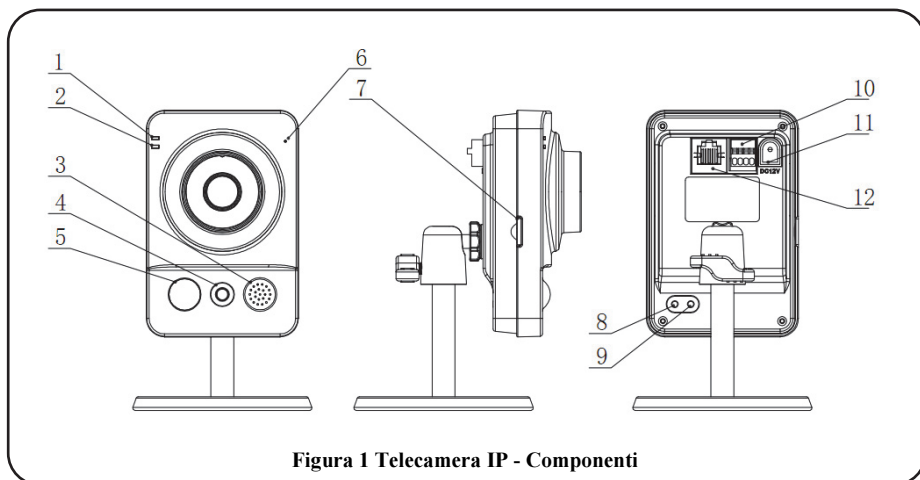
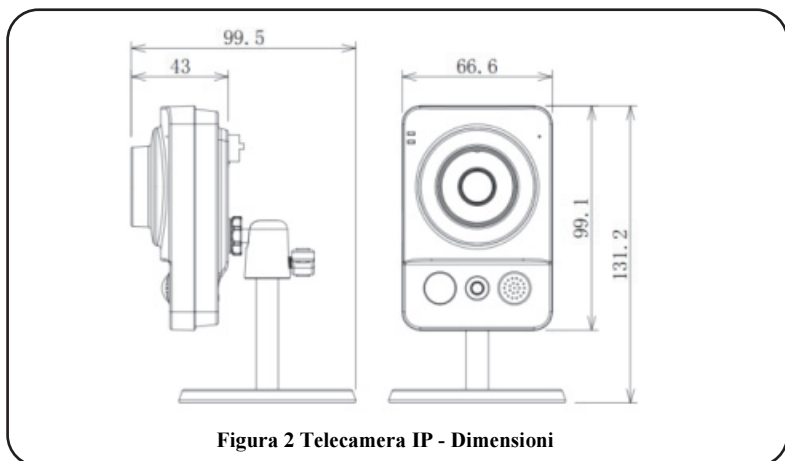

**Figura 2 Telecamera IP - Dimensioni**

## Telecamera IP - Installazione

Dopo aver letto le istruzioni di installazione e prima di installare la telecamera IP, preparare un piano per il montaggio della stessa nel sito da proteggere.

Il corretto posizionamento della telecamera IP è fondamentale per ottenere prestazioni ottimali di sicurezza-sorveglianza. In primo luogo, determinare quali devono essere le aree da proteggere e poi scegliere la locazione ottimale dove installare la telecamera IP.

**IMPORTANTE!** – Prima della installazione si raccomanda di salvare l'indirizzo MAC del dispositivo che si trova sulla scatola o sul retro della telecamera IP. Questo indirizzo verrà richiesto durante la fase di connessione alla rete del dispositivo.

Indirizzo MAC



## Montaggio della telecamera IP

La telecamera IP ha due opzioni di montaggio:

- Soffitto (Figura 3)
- Parete (Figura 4)



Figura 3 Montaggio a Soffitto



Figura 4 Montaggio a Parete

**IMPORTANTE** - Si prega di assicurarsi che la superficie di installazione possa supportare almeno 3 volte il peso della telecamera comprensiva di staffa.

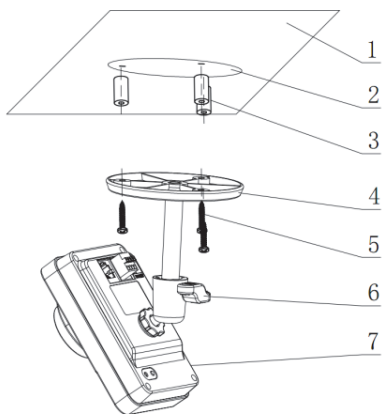
<b>Passo</b>	<b>Descrizione</b>
1	Posizionare la dima in dotazione sulla superficie dove si è previsto di installare la telecamera. (soffitto o parete).
2	Fare i buchi sulla superficie di installazione utilizzando la dima come riferimento.
3	Inserire i tasselli (in dotazione) nei fori appena fatti.
4	Posizionare la base della staffa sui fori.
5	Utilizzate un cacciavite per stringere le viti (in dotazione) e fissare fermamente la base della staffa.
6	Allentare la manopola di fissaggio sulla staffa e regolare la telecamera IP nella posizione corretta in base alle vostre reali esigenze.
7	Stringere la manopola di fissaggio per fermare la telecamera IP.

## **Alimentazione della Telecamera IP**

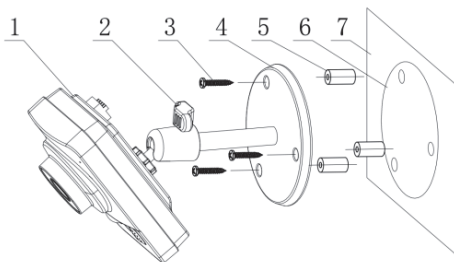
Collegare l'alimentatore (in dotazione) al connettore di alimentazione della telecamera IP.

Connettere l'alimentatore alla presa di rete elettrica. Quando la telecamera IP viene alimentata il LED verde si accende.

## **Connessione della telecamera IP alla rete**

La telecamera IP supporta diverse opzioni di connessione di rete, tra cui LAN e Wireless.

### **Connessione ad una rete LAN**

Il collegamento della telecamera IP a una rete tramite la LAN (Local Area Network) consente una facile connessione e necessita, a volte, della configurazione dell'Access Point (gateway o router).

1. Collegare il cavo di rete in ingresso alla porta Ethernet sulla telecamera IP.
2. Aspettare qualche minuto affinché la telecamera IP si connetta automaticamente al Cloud RISCO. La spia di rete rossa indica che la telecamera IP è ora pronta per la definizione delle impostazioni (Fare riferimento a Impostazioni telecamera IP - Definizione).

## Connessione ad una rete WIFI utilizzando WPS

Il collegamento della telecamera IP a una rete WIFI utilizzando WPS (Wi-Fi Protected Setup) richiede che l'AP (Punto di Accesso) e il sistema operativo supportino la modalità di connessione WPS.

---

**NOTA** – Alcuni AP (Punto di Accesso) hanno un pulsante virtuale sul loro software di gestione. (Fare riferimento alla documentazione del punto di accesso per i dettagli su come utilizzare le funzioni WPS).

---

1. Una volta che il cavo di alimentazione è collegato, attendere 1 minuto per far sì che la videocamera IP si avvii.
2. Premere e tenere premuto rispettivamente per 2 secondi il pulsante WPS sulla telecamera IP e il pulsante WPS sul punto di accesso. La spia di rete VERDE indica che la telecamera IP è ora pronta per la definizione delle impostazioni (Fare riferimento a Impostazioni - Definizione telecamera IP).

## Connessione ad una rete wireless utilizzando RISCO Cloud

L'impostazione del collegamento della telecamera IP a una rete WIFI utilizzando il Cloud RISCO (RISCO Application Server) richiede prima di collegare fisicamente la telecamera IP alla AP (Punto di Accesso) e poi, dal Cloud RISCO Application Installer di definire le impostazioni della telecamera IP e impostare la connessione WIFI. Una volta che è stata impostata la connessione WIFI, la telecamera IP può essere scollegata fisicamente dall' AP (Punto di Accesso).

1. Collegare il cavo di rete in ingresso alla porta di rete sulla telecamera IP.
2. Aspettare qualche minuto affinché la telecamera IP si connetta automaticamente al Cloud RISCO. La spia di rete rossa indica che la telecamera IP è ora pronta per la definizione delle impostazioni (Fare riferimento a Impostazioni telecamera IP - Definizione).
3. Una volta che è stata stabilita una connessione wireless, scollegare la telecamera IP dall' AP (Punto di Accesso) e installarla in qualsiasi punto all'interno dell'area da monitorare.

---

### **NOTA:**

1. Per collegare la telecamera al Cloud RISCO utilizzando il protocollo UPnP, si richiede che il router sia certificato **UPnP**. Se il router non è certificato **UPnP**, si consiglia di non utilizzare tale protocollo ed aprire manualmente le porte sul router. (vedere la sezione Risoluzione dei problemi per ulteriori informazioni).
  2. La telecamera IP non può essere collegata a più di un router.
-

# Installazione della Telecamera IP utilizzando RISCO Cloud Installer Application

Il RISCO Cloud Application Installer fornisce un'interfaccia utilizzabile da un PC locale o remoto tramite il web. Ciò consente di aggiungere telecamere IP, definirne le impostazioni e impostare gli eventi di allarme per l'attivazione.

**IMPORTANTE** – Una centrale intrusione deve essere stata precedentemente programmata sul Cloud RISCO per accedere alle telecamere IP e definirne le impostazioni (consultare il Manuale Cloud Application Installer)

## Definizione dei parametri IP della telecamera

Dopo aver collegato la telecamera IP alla rete (vedi, Collegamento della telecamera IP alla rete) è possibile definirne i parametri.

**Per definire le impostazioni della telecamera IP:**

1. Accedere all'applicazione Installer Administration Application utilizzando l'indirizzo della pagina Web fornite dal provider e inserire le proprie credenziali (nome utente e password). Nota: E' raccomandato l'utilizzo di browser quali google Chrome o Firefox per fare il login nella pagina WEB.
2. Selezionare il collegamento "Control Panels List". Viene visualizzata la pagina con l'elenco delle centrali.

CP Login ID	Web Login ID	First Name	Last Name	Cell Phone	Provider (List)	Account	Last Connected Time	Online?
TCONNECT203							7/17/2012 9:39:48 AM	No
22400000123							4/19/2012 5:34:47 PM	No
22400048768								Never
22400036472							5/14/2012 3:26:34 PM	No
22400000014							4/25/2012 9:00:11 AM	No
22400065764							5/21/2012 3:25:56 PM	No
22400000010							4/30/2012 1:11:16 PM	No
22400066013							5/2/2012 4:55:14 PM	No
22400000012							9/27/2012 1:01:38 PM	No
22400065725							9/19/2012 12:27:16 PM	No

Figure 5 Pagina "Lista Centrali"

3. Dalla pagina "Control Panels List" selezionare la centrale che si desidera visualizzare. Viene visualizzata la pagina "Control Panel Update"

**Figure 6** Pagina “Aggiornamento Centrali”

- Fare clic sul collegamento “**Network Cameras**” nella colonna di sinistra, viene visualizzata la pagina “**IP Cameras**”

**Figure 7** Lista Telecamere IP

- Cliccare su a Add Camera, viene visualizzata la finestra “**Add Camera**”.

**Figure 8** Aggiungi Telecamera

- Definire i seguenti campi nella finestra “**Add Camera**”.

Campo	Descrizione
<b>Etichetta</b>	Nome della Telecamera
<b>Partizione</b>	Selezionare la partizione/i dalla lista di quelle disponibili
<b>Tipo</b>	Scegliere il tipo di telecamera RISCO (per ONVIF o impostazioni telecamera generici, fare riferimento al manuale Cloud Application Installer)
<b>Indirizzo MAC</b>	Inserire l'indirizzo MAC, così come riportato sulla scatola o sul coperchio posteriore della telecamera IP. L'indirizzo MAC (Media Access Control) è il codice che identifica univocamente la telecamera sulla rete. <b><i>Nota: Il codice MAC va digitato esattamente come riportato sull'imballo o sulla telecamera (Maiuscole e Minuscole)</i></b>

- Fare clic su **“Add”**, se la telecamera è stata identificata con successo viene visualizzato il seguente messaggio..

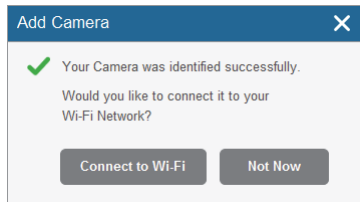

**Figure 9** La Telecamera è stata identificata correttamente

Se compare un messaggio di errore tipo **“UPnP Client error”**, fare riferimento alla sezione Risoluzione Problemi.

---

**NOTA** – Questo messaggio è rilevante solo per le telecamere IP che sono fisicamente connesse alla rete LAN tramite l’Access Point.

---

- Selezionare una delle seguenti opzioni:

**Connect to Wi-Fi** – per stabilire una connessione di rete wireless (andare al punto 9 per collegare la telecamera IP alla rete wireless).

**Not Now** –per stabilire una connessione di rete LAN (saltare la connessione di rete wireless passaggi 9, 10 e 11 e collegare la telecamera IP alla rete LAN).

- Se è stata selezionata l'opzione **“Connect to Wi-Fi”**, viene visualizzato un elenco delle reti wireless disponibili.

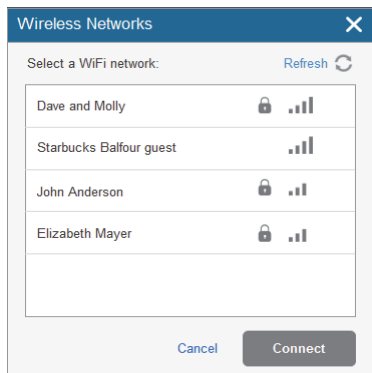

**Figure 10** Lista delle reti wireless disponibili

- Selezionare una rete wireless dall'elenco disponibile e fare clic su Connetti.

**NOTA** – Se la rete è protetta da password, la password deve essere immessa nella schermata visualizzata.

11. Fare clic su “**Connect**” per stabilire la connessione wireless (Consultare Connessione a una rete wireless utilizzando RISCO Cloud).

**IMPORTANTE** – Una volta che è stata stabilita una connessione wireless, non dimenticare di scollegare la telecamera IP dall’Access Point

Una volta che la "telecamera è pronta per l'uso" viene visualizzato un messaggio, fare clic su OK. La telecamera IP viene visualizzata nella pagina IP Cameras

## IP Cameras













Label	Partition	Type	MAC Address	Wi-Fi	Actions
Main Entrance cam	Lobby Floor	RISCO	00-10-5A-44-12-B5	Connected	 
Front yard cam	Lobby Floor, Storage Rooms	RISCO	00-10-2B-36-11-18	Connect	 
Lobby cam	Lobby Floor	Generic	11-10-5A-44-12-B5	Connect	 
Living Room	Storage Rooms	ONVIF	07-10-5A-4A-28-B6	Connected	 
Second Floor north cam	Storage Rooms	ONVIF	00-10-5A-44-12-B5	Connected	 
Basement	Sun Microsystems	RISCO	03-10-5A-44-12-B5	Connected	 

Figura 11 Lista telecamere IP

**NOTA** – Esiste la possibilità di editare  o cancellare  la telecamera IP selezionata

## Definizione dei parametri di attivazione della telecamera IP

Qualsiasi evento del seguente elenco può essere utilizzato per attivare un allarme

Eventi di Partizione			
Allarme Incendio	Allarme Panico	Allarme Medico	Allarme
Inserimento Totale	Inserimento Parziale	Disinserimento	Coercizione
Tamper	Allarme 24 HR	Allarme Allagamento	Allarme Gas
Allarme Ambientale	Allarme no movimento	Bassa Temperatura	Allarme Uscita
Eventi di Sensore			
Allarme	Zone Escluse	Zone Incluse	Zone Tamper



## Per definire i parametri di attivazione:

1. Dalla pagina di Controllo Centrale/Telecamere , fare clic sulla scheda **Trigger**, la telecamera attiva viene visualizzata.



Figura 12 Lista Attivazioni Telecamere

2. Fare clic su “Add trigger”; la finestra **Add Trigger** viene visualizzata

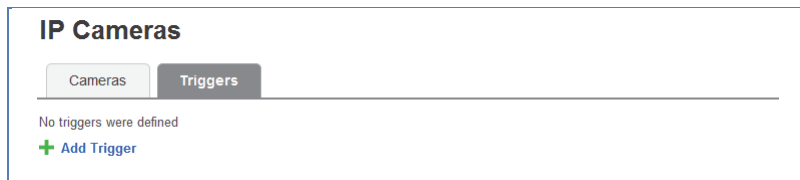

Figura 13 Aggiungi Attivazioni

3. Definire i seguenti campi nella finestra **Add Trigger**.

Campo	Descrizione	Tipo Evento
<b>Etichetta</b>	Nome Attivazione	Eventi per partizione/sensori
<b>Telecamera</b>	Scegliere la Telecamera dalla lista	Eventi per partizione/sensori
<b>Tipo Evento</b>	Scegliere la tipologia di evento dalla lista	Eventi per partizione/sensori
<b>Evento</b>	Scegliere il tipo di evento dalla lista (Es. Rapina, allarme, ecc. ecc.)	Eventi per partizione/sensori

Campi aggiuntivi possono essere visualizzati nella finestra di dialogo **Add trigger** in base al tipo di evento che si è selezionato (vedi esempi sotto).

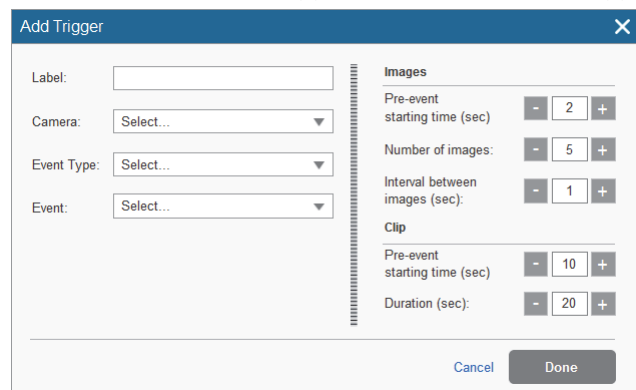

Figura 14 Aggiungo Attivazione per Partizione

Figura 15 Aggiungo Attivazione per sensore

- Definire i seguenti campi nella finestra di dialogo **Add trigger** in base al tipo di evento che si è selezionato.

Campo	Descrizione	Tipo Evento
<b>Partizione(i)</b>	Selezionare la partizione(i) dalla lista. <b>NOTA</b> – Vengono visualizzate solo le partizioni associate alla telecamera.	Solo Eventi per Partizione
<b>Sensori</b>	Selezionare il sensore dalla lista	Solo Eventi per Sensori
<b>Eventi</b>	Selezionare l'evento dalla lista	Eventi per Partizione/Sensori

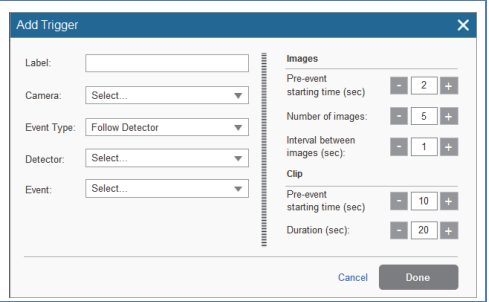
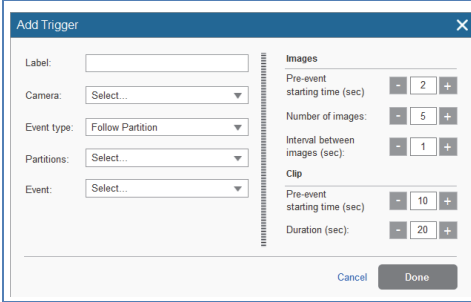
- Definire le seguenti impostazioni per Immagine(Foto)/clip (video) :









Campo	Descrizione
<b>Immagini (still)</b>	<b>Pre-event starting time (sec)</b> – time, before the actual event occurred, to start displaying still images. <b>Number of images</b> – number of still images to display. <b>Interval between images (sec)</b> – time required between each still image.
<b>Clips (video)</b>	<b>Pre-event starting time (sec)</b> – time, before the actual event occurred, to start displaying video clip. <b>Duration (sec)</b> – total duration of the video clip Nota: Questi campi sono attualmente bloccati ed i parametri di default non possono essere modificati

6. Una volta terminato, fare clic su “Done”. L’attivazione telecamera definita viene visualizzata nella pagina **Camera Triggers List**.

## IP Cameras



Cameras Triggers

+ Add Trigger

Label	Event	Camera	Camera Operations	Actions
Lobby floor alarm	Partition - Lobby Floor Alarm Follow	Street cam North	3 images, 10 seconds clip	  
Storage Tamper	Partition - Storage Rooms Tamper Follow	Street cam South	1 image	  
Lobby Arming	Detector - Lobby South-East Arm Follow	Lobby main cam	5 images, 20 seconds clip	  

Duplicate

**Figure 16** Elenco Attivazioni Telecamera

**NOTA** – Esiste la possibilità di editare  , duplicare  , o cancellare  l’attivazione per la telecamera selezionata.

**IMPORTANTE** – Non possono essere definite due attivazioni uguali per la stessa telecamera. In questo caso almeno una delle due attivazioni o entrambi devono essere modificate.

## Errori sulla configurazione Internet UPnP

Non tutti i router supportano il protocollo UPnP e in alcuni router questa funzionalità viene disabilitata per scelta. Se si è tentato di configurare automaticamente la connessione della telecamera su Internet, e appare il messaggio "Errore UPnP Client" o errori simili, bisogna impostare manualmente la connessione sia sulla telecamera che sul router.

### Passo 1: Indirizzo IP della Telecamera

Utilizzare l'interfaccia del router per identificare l'indirizzo IP della telecamera. L'interfaccia del router solitamente può essere aperta utilizzando qualsiasi Web Browser.

1. Inserire l'indirizzo IP locale del router nel campo indirizzi del browser. Viene visualizzata la pagina di accesso del router.
2. Inserire username e password nel box e fare clic su OK / Login.

**NOTA: Per ulteriori informazioni su come navigare sul router specifico, controllare il manuale utente del proprio router.**

3. Trovare la Tabella DHCP.

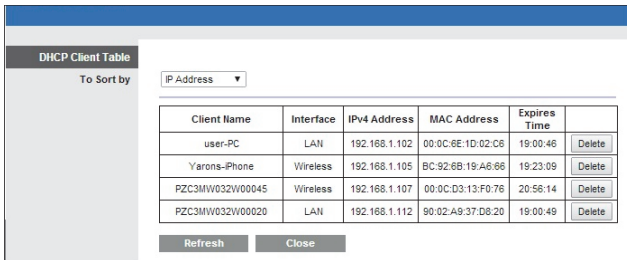

Client Name	Interface	IPv4 Address	MAC Address	Expires Time	
user-PC	LAN	192.168.1.102	00:0C:6E:1D:02:C6	19:00:46	Delete
Yarons-Phone	Wireless	192.168.1.105	BC:92:6B:19:A6:66	19:23:09	Delete
PZC3MV032W00045	Wireless	192.168.1.107	00:0C:D3:13:F0:76	20:56:14	Delete
PZC3MV032W00020	LAN	192.168.1.112	90:02:A9:37:D8:20	19:00:49	Delete

Figura 17 Esempio Tabella DHCP

4. Prendere nota dell'indirizzo IP della telecamera che si vuole configurare manualmente.

### Passo 2 : Impostazioni Telecamera

Utilizzare l'interfaccia della fotocamera per impostare la fotocamera. L'interfaccia della fotocamera può essere aperta utilizzando qualsiasi Web Browser.

1. Digitare l'indirizzo IP della telecamera nel campo dell'indirizzo del browser per aprire l'interfaccia della Telecamera.
2. Quando viene visualizzata la pagina di login, inserire la User e Password nei relativi campi e fare clic su Login.

**NOTA – Di Default la User e la Password sono “admin”. Una volta che la telecamera si è connessa al Cloud la password viene automaticamente modificata in “ AdmiN + Indirizzo MAC Telecamera” (es. AdmiN AABBCDDDEEFF).**

1. Una volta effettuato il Login selezionare Setup > Network > UPnP. I parametri UPnP vengono visualizzati.

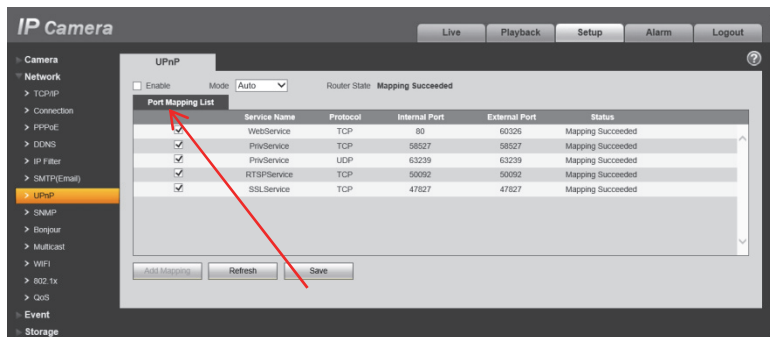

**Figura 18 Parametri UPnP**

2. Deselezionare la casella “Enable” e cliccare su “Save”
3. Selezionare TCP/IP. La pagina parametri TCP/IP è visualizzata.

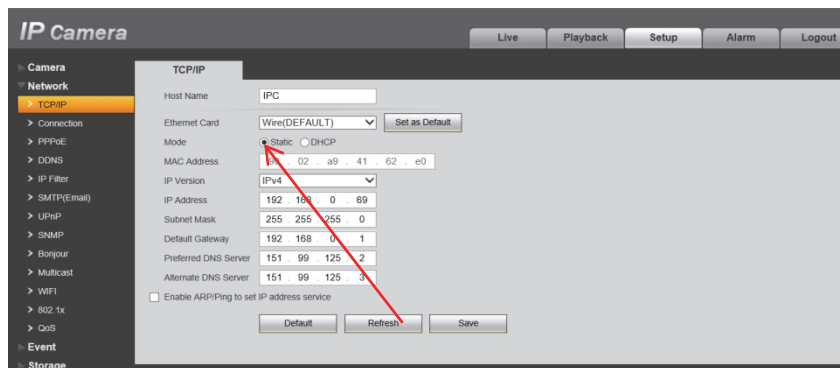

**Figura 19 Parametri TCP/IP**

4. Selezionare modo “Static” e inserire tutti i dati relativi alla propria rete per poter effettuare la connessione ad Internet.
5. Cliccare su “Save”

6. Selezionare Connection. La pagina parametri Connessione è visualizzata.



Figura 20 Parametri di Connessione

7. Inserire per ogni protocollo (TCP, UDP, HTTP, RSTP, HTTPs) il numero di porta che si intende utilizzare. Successivamente attraverso il Router queste porte dovranno essere aperte sia in ingresso che in uscita.

<b>TCP Port</b>	Impostare la porta TCP che si vuole definire per la telecamera (nel nostro esempio la 47777).
<b>UDP Port</b>	Set the UDP port (nel nostro esempio 47778)
<b>HTTP Port</b>	Di Default la porta HTTP per la connessione alla telecamera via WEB è settata su 80 (standard). Si consiglia di cambiare anche questa porta. Ricordarsi che una volta modificata la porta HTTP, per connettersi alla telecamera via web la sintassi è la seguente: "Indirizzo IP:Nuova porta
<b>RTSP Port:</b>	Di default la porta è la 554 (nel nostro esempio la 47554).
<b>HTTPS Port</b>	La porta di default è la numero 443, e può essere cambiata con qualsiasi altra porta dalla 1024 alla 65535 (nel nostro esempio la 47443).

8. Cliccare su Save

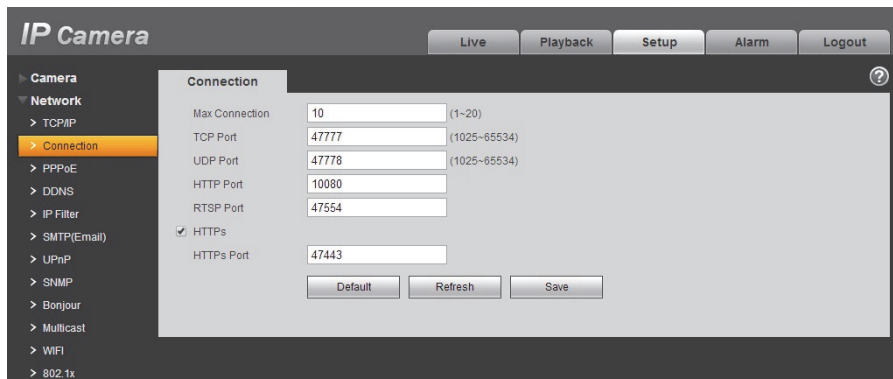
9. Ripetere i passi appena descritti per aggiungere ulteriori telecamere, ricordandosi di utilizzare **Indirizzi IP differenti e Porte differenti per ogni Telecamera.**

### Passo 3: Apertura porte sul Router (Forwarding)

Di default le caratteristiche di sicurezza su molti router impediscono l'accesso ai dispositivi installati in casa/Azienda attraverso Internet. Per aprire una porta, è necessario abilitare il "port forwarding" sul router. Visto la varietà di Router in commercio, le interfacce grafiche potranno sicuramente variare, ma in genere, per aprire una porta si dovrebbe procedere nel seguente modo:

1. Ritornare nell'interfaccia WEB del Router

**NOTA: Per ulteriori informazioni su come navigare sul router specifico, controllare il manuale utente del router.**

2. Navigate nei vari menù (solitamente impostazioni avanzate) fino a trovare il Port Forwarding.



Figura 21 Esempio di pagina per il Port Forwarding

**Nota: In questo specifico caso si possono specificare per un particolare indirizzo IP le porte da aprire.**

3. Per la Telecamera selezionata inserire tutte le porte da aprire che sono state precedentemente settate nel Passo 2.

47777	47777	TCP ▼	192.168.1.122	<input checked="" type="checkbox"/>
47778	47778	UDP ▼	192.168.1.122	<input checked="" type="checkbox"/>
10080	10080	TCP ▼	192.168.1.122	<input checked="" type="checkbox"/>
47554	47554	TCP ▼	192.168.1.122	<input checked="" type="checkbox"/>
47443	47443	TCP ▼	192.168.1.122	<input checked="" type="checkbox"/>

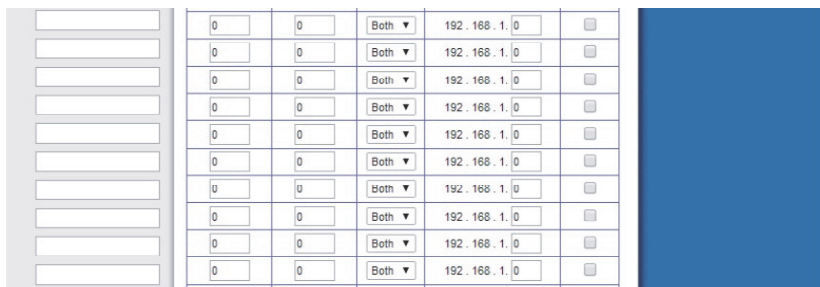
Figura 22 Esempio di inserimento dati per il Port Forwarding

**Nota: per i protocolli HTTP, RSTP e HTTPs sulle porte assegnate è sufficiente aprire il protocollo TCP**

4. Salvare la configurazione sul proprio Router
5. Disalimentare e rialimentare la telecamera.
6. Ripetere la sopra descritta procedura per ogni telecamera installata ricordandosi di utilizzare **Indirizzi IP differenti e Porte differenti per ogni Telecamera.**

## Specifiche Tecniche

Parametri		
Sistema	Processore	TI Davinci alte prestazioni DSP
	OS	Embedded LINUX
	Risorse Sistema	Supporta connessione real-time della rete, registrazione locale e operazioni remote simultaneamente.
	Interfaccia Utente	Operazioni remote attraverso interfaccia WEB, DSS, PSS. simultaneamente
	Stato Sistema	Statistiche traffico, Log, Versione Software
Parametri Video	Sensore Video	1/3-inch CMOS
	Pixel	1280(H)*960(V)
	Gain Control	Fisso/Automatico
	Bilanciamento Bianco	Manuale/Automatico
	BLC	On/Off
	Modo Esposizione	Manuale/Automatico PAL: It ranges from 1/3 to 1/10000. NTSC: It range da 1/4 to 1/10000.
	Video Frame Rate	PAL: Main stream(1280*960@15fps) extra stream(352*288@15fps) Main stream(1280*720@25fps) extra stream(352*288@25fps) NTSC: Main stream(1280*960@15fps) extra stream(352*240@15fps) Main stream(1280*720@30fps) extra stream(352*240@30fps)
	Video Bit Rate	H.264: 56Kbps-6144Kbps MJPEG regolabile e Bit Rate regolabile. Supporto personalizzato.
	Video Flip	Supporta funzione mirror. Supporta funzione flip.
	Foto	Massimo 1f/s. L'estensione del file è JPEG.
	Zone di mascheramento	Supporta un massimo 4 zone di mascheramento immagine
	Video Setup	Impostazione dei parametri quali luminosità e contrasto.
	Informazioni Video	Titolatura canale, titolatura Ora, rilevatore movimento, mascheramento
Lente	3.6mm. Fuoco Fisso. Angolo di visione: 70°(H) *51.5°(V)	
Lens Interface	M12. Lens is the default accessories	
Audio	Stream Audio	Dual-way
	Audio ingresso/Uscita	Altoparlante e Microfono inclusi
	Audio Bit Rate	8kbps 16bit
	Compressione Audio	G.711A/G.711Mu/PCM
Video	N/A	N/A
	Mascheramento Telecamera	Livello di sensibilità variabile da 1 a 6. Ciascun livello di sensibilità è la percentuale della zona di mascheramento. Evento Attivazione: Allarme, archiviazione audio/video, immagini snapshot, funzione SMTP email, ecc
Porte		1-Ingresso e 1-Uscita (on-off)



Parameteri			
Backup e Registrazione	Priorità registrazione	Supporta solo registrazione remota	Manuale>Rileva Video>Programmazione
	SD Card	Supporta scheda Micro SD (Minimo 4GB)	
	Storage Management	Visualizzazione attraverso rete dello stato di archiviazione.	
Network	Rete Cablata	1 ingresso porta Ethernet, 10/100 Base-T Ethernet	
	Rete Wireless	IEEE802.11a/b/g/n, con antenna interna	
	Protocolli di Rete	Standard HTTP, TCP/IP, ARP, IGMP, ICMP, RTSP, RTP,UDP, RTCP, SMTP, FTP, DHCP, DNS, DDNS, PPPOE, UPNP, NTP, Bonjour, SNMP.	
	Operazioni Remote	Monitoraggio, Impostazione Sistema, Scarico File, Informazioni di accesso, manutenzione, upgrade ecc.	
Porte Ausiliarie	Compensazione Della Luminosità	Attivazione automatica IR quando la luminosità dell'ambiente diventa insufficiente	
	N/A	N/A	
	WPS	Pulsante per abilitazione connessione WIFI	
Parametri Generali	Alimentazione	DC 12V	
	Consumo	6W MAX	
	Temperatura di lavoro	-10 ~+50	
	Umidità sopportata	10%~90%	
	Dimensioni(mm)	66.6*99.5*131.2	
	Peso	229g (box escluso)	
	Installazione	Installazione con staffa.	

## NOTE

# VUpoint Cámara IP “cube” de interior



**Modelo: RVCM11H**

**ES**

**Guía de instalación**

## Precauciones de seguridad

Estas instrucciones están indicadas para asegurar que el usuario puede utilizar el producto correctamente para evitar daños personales o materiales.

### AVISOS:

- La instalación o el empleo de este producto que no se realice de acuerdo con el uso indicado por el suministrador y tal y como está descrito en las instrucciones puede resultar en daños, lesiones o muerte.
- Asegúrese que este producto no es accesible a niños y aquellas personas para las cuales su operativa no está dirigida.
- Toda la instalación y la operativa debe ser conforme a sus normas de seguridad eléctrica. La alimentación debe cumplir con el requisito de tensión mínima de seguridad SELV (Safety Extra Low Voltage) con un valor de 12V DC según la norma IEC60950-1.
- Si el dispositivo va a estar permanentemente conectado a la electricidad, debería tener una conexión que incluya un dispositivo de desconexión fácilmente accesible, como un interruptor automático. No conecte dos fuentes de alimentación al dispositivo a la vez, puede ocasionar daños a la cámara IP.
- No intente bajo ningún concepto reparar el dispositivo por su cuenta ya que puede resultar en daños, lesiones o muerte – siempre contacte con su instalador o suministrador para cualquier avería.

### ATENCIÓN:

- Asegúrese de que el voltaje de la alimentación es el adecuado antes de usar la cámara.
- No deje caer la cámara ni la someta a ningún tipo de impacto.
- No toque los sensores con los dedos. Si es necesario limpiarlos use un trapo limpio mojado ligeramente en alcohol y empléelo cuidadosamente.
- No oriente la lente de la cámara a una fuente de luz potente como el sol o una lámpara incandescente. Puede causar un daño irreparable a la cámara.
- El sensor se puede quemar por el uso de un láser, por este motivo si cualquier equipamiento que disponga de láser se va a emplear cerca de la cámara, asegúrese de que la superficie del sensor no está expuesta al mismo.
- No coloque la cámara en entornos de temperatura extremos (la temperatura de operación se debe encontrar entre el rango -10 °C a 50 °C).
- Para evitar el sobrecalentamiento de la cámara, se recomienda operar la misma en un entorno que disponga de una buena ventilación.
- Mantenga la cámara lejos de cualquier tipo de líquido.
- Durante su distribución la cámara debe estar empaquetada en su embalaje original.

NOTA: No se asume ningún tipo de responsabilidad derivada de cualquier tipo de fuego o daño eléctrico o electrocución debida a un manejo o instalación incorrecto. No se asume ningún tipo de responsabilidad causada por modificaciones o intentos de reparaciones no autorizadas.

## Introducción

RISCO Group presenta VUpoint, una revolucionaria solución de vídeo verificación que integra fácilmente Cámaras IP con los sistemas de seguridad profesional de RISCO. Impulsado por RISCO Cloud, VUpoint proporciona un nivel de seguridad y vídeo verificación en vivo sin precedentes para centrales receptoras y usuarios finales por igual. La cámara “cube” de interior de RISCO es una parte importante de esta solución y es fácilmente controlada a través de las aplicaciones web y de dispositivos móviles.

## Características

- Instalación Plug & Play
- 1.3” Megapíxeles
- Color HD
- Ranura para tarjeta SD para almacenamiento local
- WiFi
- LED IR (7-10m)

## Componentes y Accesorios

Cámara IP RISCO y soporte:



Adaptador (no suministrada con la cámara) con bolsa de accesorios:



Guía de instalación:



## Requerimientos mínimos de la red Internet:

- 750 Kbps velocidad de subida (por cámara)
- 5 Mbps velocidad de bajada

**RECOMENDACION** – Puede instalar más de una cámara con los requerimientos mínimos recomendados (750 Kbps por cada cámara) pero tenga en cuenta que la visión de múltiples cámaras en paralelo puede reducir la velocidad de refresco y la calidad de la imagen.

## Componentes y Dimensiones de la Cámara IP



Figura 1 Componentes de la Cámara IP

Etiqueta	Nombre	Indicador	Conector	Descripción
1	Luz de indicador de alimentación	POWER	/	<ul style="list-style-type: none"> <li>• Cuando se enciende – la luz verde se activa.</li> <li>• Cuando se está actualizando – la luz verde parpadea. Intervalo de 0,5 segundos.</li> <li>• Cuando está en alarma – la luz verde parpadea. Intervalo de 0,2 segundos.</li> </ul>
2	Luz de indicador de red	NET	/	<ul style="list-style-type: none"> <li>• Conexión cableada – la luz roja está activada.</li> <li>• Conexión inalámbrica – la luz verde está activada.</li> </ul>
3	Altavoz	/	/	Señal de salida de audio (esta función es opcional).
4	Sensor fotoeléctrico	/	/	Puede activar detección de movimiento, personas mediante PIR, alarma externa.
5	N/A	N/A	N/A	N/A

Etiqueta	Nombre	Indicador	Conector	Descripción
6	Micrófono	/	/	Recibe señal de audio directa (esta función es opcional).
7	Tarjeta Micro SD	Micro SD	Ranura para tarjeta Micro SD	Almacenamiento en tarjeta SD. Requisitos: Tipo: clase 4. Memoria: hasta 64GB. <b>NOTA:</b> Añadir la tarjeta micro SD permite grabar vídeo. Para introducir o reemplazar la tarjeta micro SD, la cámara debe estar apagada.
8	Botón reset	Reset	/	Restaura los valores por defecto de fábrica. Cuando el dispositivo esté funcionando normalmente, presione el botón durante al menos 5 segundos para restaurarlos.
9	Botón WPS	WPS	Conexión inalámbrica rápida	Pulse el botón WPS del router y del dispositivo respectivamente durante al menos 2 segundos. Puede tardar hasta 1 minuto. Por favor, note que sólo es válido para router con funcionalidad WPS.
10	N/A	N/A	N/A	N/A
11	Alimentación	DC12V	/	Alimentación de 12V.
12	Red	LAN	Ethernet	Conectar cable Ethernet.

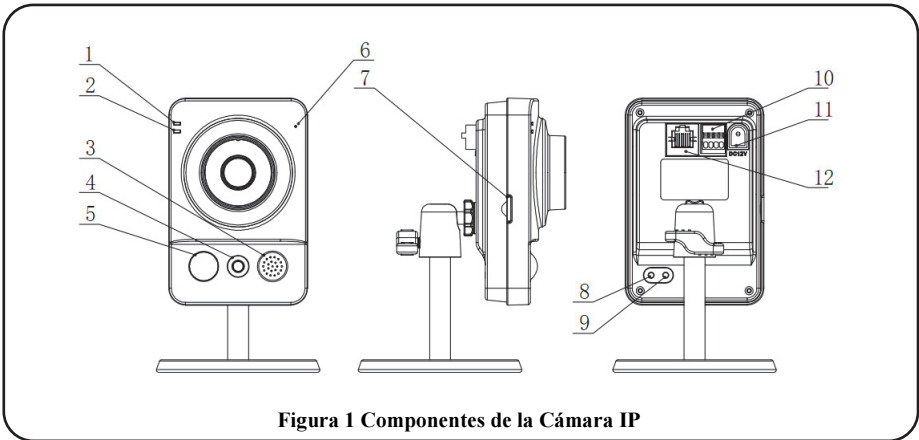
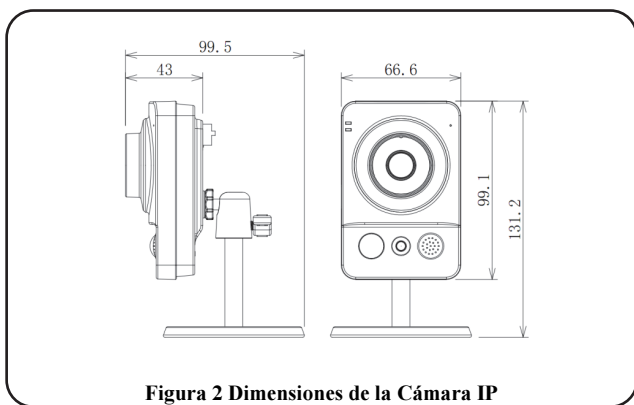

**Figura 2 Dimensiones de la Cámara IP**

## Instalación de la Cámara IP

Después de leer las instrucciones de instalación y antes de instalar su cámara, planifique el montaje de la misma en la localización elegida. La correcta colocación de su cámara IP es crucial para un rendimiento óptimo de la monitorización. En primer lugar, determine qué áreas deben ser protegidas y seguidamente planifique cuáles son las zonas óptimas para instalar su cámara IP.

**¡IMPORTANTE!** – Por favor, tome nota de la dirección MAC impresa en la caja o en la parte trasera de la cámara IP antes de la instalación. Puede necesitarla durante la fase de conexión a la red.

Dirección MAC



**RISCO** 14 Hachoma St.  
Rishon Le Zion,  
ISRAEL

CE  
FC  
SSTN1778

PN: RVC11H0000A  
IP Cam: Indoor, Hyb, 1.3MP, POE, 2.4G  
INPUT: 12V, 0.5A FCC ID: SVNIPC-K100

MAC: AA:BB:CC:DD:EE:FF

SIN: XXXXXXXXXXXXXXXX

Made in China

## Montaje de la Cámara IP

La cámara IP soporta dos tipos de montaje distintos; para techo y pared (figuras 3 y 4 respectivamente).



Figura 3 Montaje de techo



Figura 4 Montaje de pared

**¡IMPORTANTE!** – Por favor, asegúrese de que la superficie de instalación puede soportar como mínimo 3 veces el peso de la cámara y del soporte.

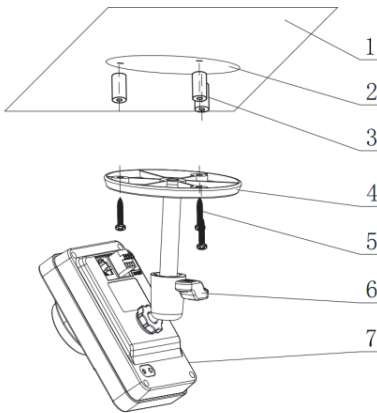

<b>Paso</b>	<b>Descripción</b>
1	Coloque la plantilla de instalación en la superficie del techo o pared.
2	Realice los agujeros en la superficie de acuerdo con la plantilla.
3	Saque de la bolsa de accesorios los tacos e insértelos en los agujeros.
4	Posicione la base de la cámara IP sobre los agujeros.
5	Saque de la bolsa de accesorios los tornillos y atornille la cámara IP firmemente.
6	Afloje la palomilla y la rótula para ajustar la cámara IP y posicionarla de acuerdo a sus necesidades de vídeo vigilancia.
7	Apriete la palomilla y la rótula para fijar la cámara IP.

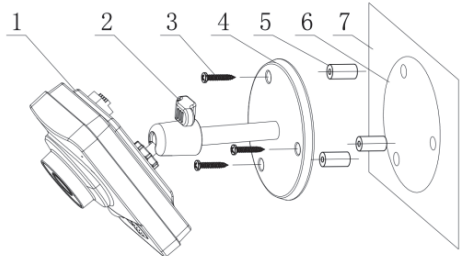
## **Conectar a la alimentación la Cámara IP**

1. Conecte el adaptador de alimentación proporcionado a la conexión de alimentación de la cámara IP.
2. Conecte el adaptador de alimentación a una toma de corriente. Cuando la cámara IP arranque, la luz VERDE del indicador POWER se iluminará.

## **Conectar la Cámara IP a la red**

La cámara IP soporta diferentes opciones de conexión a la red incluyendo cableada e inalámbrica.

### **Conectar a una red local cableada**

Conectar la cámara IP a la red usando el puerto LAN (Local Area Network) permite una configuración sencilla y compatible con puntos de acceso como, por ejemplo, un gateway o un router.

1. Conecte el cable de red al puerto de red de la cámara IP etiquetado LAN.
2. Espere unos minutos mientras la cámara IP se conecta automáticamente con RISCO Cloud. La luz ROJA del indicador de red muestra que la cámara IP está lista para configurar los parámetros.

## Conectar a una red inalámbrica empleando WPS

Conectar la cámara IP a una red inalámbrica usando WPS (Wi-Fi Protected Setup) requiere que el router y el sistema operativo soporten esta funcionalidad.

---

**NOTA** – Algunos routers tienen un botón virtual en su sistema de administración (Acceda a la documentación del router para conocer los detalles de funcionamiento de WPS).

---

1. Una vez que la alimentación esté conectada, espere 5 minutos para que la cámara arranque totalmente.
2. Mantenga pulsado el botón de WPS de la cámara IP y el botón WPS del router respectivamente durante 2 segundos. La luz indicadora en VERDE muestra que la cámara IP está preparada para definir la configuración de la cámara.

## Conectar la red inalámbrica mediante RISCO Cloud

Conectar la cámara IP a una red inalámbrica usando RISCO Cloud (RISCO Application Server) requiere que primeramente se haya conectado físicamente la cámara IP al router y, a continuación, desde RISCO Cloud se defina la configuración de la cámara IP y se establezca la conexión inalámbrica. Una vez que la conexión inalámbrica se ha establecido, se puede desconectar el cable del router y proceder a instalarla.

1. Conecte el cable de red al puerto LAN en la cámara IP.
2. Espere 5 minutos mientras la cámara conecta automáticamente con RISCO Cloud (RISCO Application Server). La luz indicadora ROJA muestra que la cámara IP está preparada para ser configurada.
3. Una vez la conexión inalámbrica se ha establecido, desconecte el cable de red de la cámara IP y del router e instálela en su lugar definitivo para la monitorización.

---

### **NOTAS:**

1. Para conectar la cámara IP a la nube de RISCO vía UPnP, el router debe ser certificado UPnP. Si el router no está certificado UPnP, le recomendamos no utilizar UPnP y abrir los puertos de la cámara manualmente en el router (Para más información vea la sección Resolución de problemas).
  2. La cámara IP no puede conectarse a más de un router.
-

# RISCO Cloud Installer Application y la cámara IP

La aplicación RISCO Cloud Installer Application proporciona una interfaz de gestión para el panel de control desde un PC local o a través de la web. Permite añadir cámaras IP y definir y configurar eventos de trigger.

**IMPORTANTE** – El panel de control se debe haber dado de alta previamente en RISCO Cloud para que se puedan añadir cámaras IP y configurar los ajustes de la cámara (acceda a su manual de gestión de RISCO Cloud para conocer más detalles).

## Definir la configuración de la cámara IP

Una vez haya conectado la cámara IP a la red (según se explica en los apartados anteriores del manual), se puede definir la configuración de la cámara.

**Para definir la configuración de la cámara IP:**

1. Acceda a la web de RISCO Cloud usando la web de Administración y el usuario y la contraseña suministrada por su distribuidor o administrador.

**NOTA** – Es recomendable emplear Google Chrome o Mozilla Firefox para acceder a la web de administración. Los menús pueden variar ligeramente frente a las imágenes mostradas.

2. Seleccione la opción de Control Panels List. Se mostrará la página de Control Panels List con los paneles a los que se tenga acceso.

Users List | Service Providers List | Control Panels List | Statistics | Services Info | Logout

Customization | Configurations | Control Panels Groups | Email & SMS Settings | SMS/Email Traffic | Licenses

Control Panels from group All Panels (Page 1/4)

Find Control Panels where Last Name begins with [Find]

CP Login ID	Web Login ID	First Name	Last Name	Cell Phone	Provider (1st)	Account	Last Connected Time	Online?
TCONNECT203							7/17/2012 9:39:48 AM	No
22400000123							4/19/2012 5:34:47 PM	No
22400048768								Never
22400036472							5/14/2012 3:26:34 PM	No
22400000014							4/25/2012 9:00:11 AM	No
22400065764							5/21/2012 3:25:56 PM	No
22400000010							4/30/2012 1:11:16 PM	No
22400066013							5/2/2012 4:55:14 PM	No
22400000012							9/27/2012 1:01:38 PM	No
22400065725							9/19/2012 12:27:16 PM	No

New Customer

Note: A new panel shall be automatically assigned to the currently selected CP group.

10 >>>

Figura 5 Página de Control Panel List

3. Desde la página de Control Panels List, seleccione el panel de control que desee. La página de Control Panels Update se mostrará.

**Figura 6** Página de Control Panel Update

- Haga clic en Network Cameras en el menú de la izquierda; la página de IP Camera List se mostrará.

**Figura 7** Listado de cámaras IP

- Haga clic en Add Camera; la ventana de Add Camera se mostrará.

**Figura 8** Add Camera

- Defina los siguientes campos de la ventana Add Camera.

Campo	Descripción
<b>Label</b>	Nombre de la cámara.
<b>Partitions</b>	Seleccione las particiones del listado de particiones.
<b>Type</b>	Escoja RISCO como tipo de cámara.
<b>MAC Address</b>	<p>Introduzca la dirección MAC en este campo. La dirección MAC (Media Access Control) es un identificador único asignado a la cámara IP para las comunicaciones de red.</p> <p><b>NOTA:</b> La dirección MAC se debería introducir exactamente como se muestra en la caja o en la etiqueta de la cámara IP, por ejemplo, AA:BB:CC:DD:EE:FF</p>

7. Haga clic en Add.

Si la cámara ha sido identificada correctamente (“Your camera was identified successfully”) el siguiente mensaje se muestra y se puede ir al paso 8.

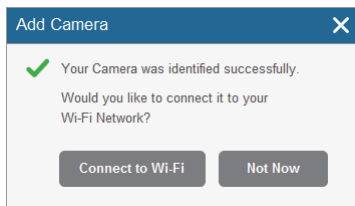

**Figura 9 Mensaje de que la cámara ha sido identificada correctamente**

Si se muestra el mensaje “unable to configure Internet Access”, “UPnP Client Error” u otro similar, acceda a la sección de Resolución de problemas.

---

**NOTA** – Este mensaje sólo es relevante para cámaras IP que se han conectado directamente desde el puerto LAN al router.

---

8. Seleccione una de las siguientes opciones:

**Connect to Wi-Fi** – para seleccionar una conexión inalámbrica en ese momento (vaya al paso 9).

**Not Now** – para seleccionar la conexión cableada del puerto LAN (omite los pasos 9, 10 y 11 y mantenga la conectividad cableada del puerto LAN)

9. Si ha seleccionado la opción “Connect to Wi-Fi”, una lista de redes inalámbricas disponibles para la cámara se muestra.



**Figura 10 Lista de redes inalámbricas disponibles**

10. Selecciona la red inalámbrica de la lista de redes disponibles y haga clic en Connect.

**NOTA** – Si su red inalámbrica está protegida con contraseña, deberá introducirla a continuación.

11. Haga clic en OK y establezca la conexión.

**IMPORTANTE** – Una vez que la conexión inalámbrica se ha establecido, no olvide desconectar el cable de red de la cámara IP del router.

12. Cuando se muestre el mensaje “camera is ready for use”, haga clic en OK. La cámara IP se mostrará en el listado de cámaras IP.

## IP Cameras

Label	Partition	Type	MAC Address	Wi-Fi	Actions
Main Entrance cam	Lobby Floor	RISCO	00-10-5A-44-12-B5	Connected	
Front yard cam	Lobby Floor, Storage Rooms	RISCO	00-10-2B-36-11-18	Connect	
Lobby cam	Lobby Floor	Generic	11-10-5A-44-12-B5	Connect	
Living Room	Storage Rooms	ONVIF	07-10-5A-4A-28-B6	Connected	
Second Floor north cam	Storage Rooms	ONFIV	00-10-5A-44-12-B5	Connected	
Basement	Sun Microsystems	RISCO	03-10-5A-44-12-B5	Connected	

Figura 11 Lista de cámaras IP

**NOTA** – También dispone de la opción para cambiar o borrar la cámara IP deseada.

## Configurar los eventos de Trigger

Cualquier evento de la siguiente lista se puede definir para activar un trigger.

Eventos asociados a particiones			
Fire Alarm	Panic Alarm	Medical Alarm	Alarm
Full Arm	Part Arm	Disarmed	Duress
Tamper	24 HR-X Alarm	Water Alarm	Gas Alarm
Environ. Alarm	No Motion Alarm	Exit Alarm	Low Temperature
Eventos asociados a zonas			
Alarm	Zone Bypassed	Zone Un-bypassed	Zone Tamper

## Para definir la configuración de los triggers:

1. Desde la página de Control Panel Camaras, haga clic en la pestaña Triggers, y la página de Camera Triggers List se mostrará.



Figura 12 Listado de Triggers

2. Haga clic en Add Trigger; la ventana de Add Triggers se mostrará.

Figura 13 Añadir un Trigger

3. Defina los siguientes campos en la ventana de Add Trigger:

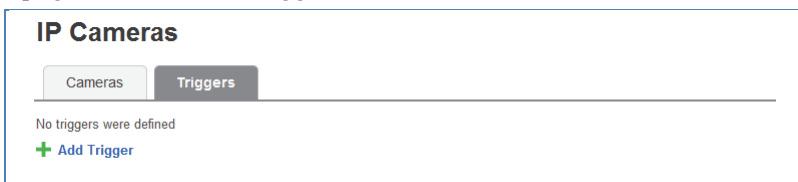
Campo	Descripción	Tipo de evento
Label	Nombre del trigger	Eventos de partición y zonas
Camera	Elija la cámara del listado	Eventos de partición y zonas
Event Type	Elija un tipo de evento	Eventos de partición y zonas
Event	Elija el evento del listado mostrado	Eventos de partición y zonas

Se muestran campos adicionales en la ventana de Add Trigger dependiendo del tipo de evento que se ha seleccionado (las figuras muestran ejemplos para tipos asociados a particiones y a zonas).



Figura 14 Trigger asociado a una partición



Figura 15 Trigger asociado a una zona

4. Defina los siguientes campos en la ventana de Add Trigger dependiendo del tipo de evento que se ha seleccionado.

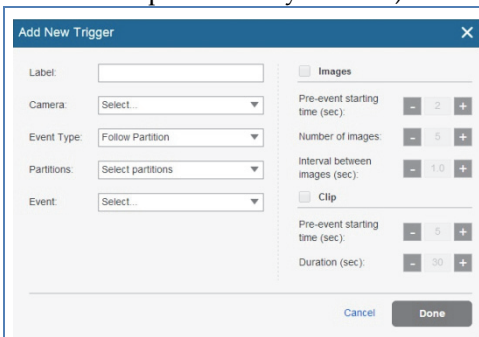
Campo	Descripción	Tipo de evento
Partition(s)	Seleccione la(s) partición(es) del listado. <b>NOTA</b> – Sólo las particiones que se han asociado a la cámara se muestran	Sólo eventos de partición
Detectors	Seleccione la zona del listado	Sólo eventos de zona

5. Defina el tipo de imagen o clip (grabación) de video

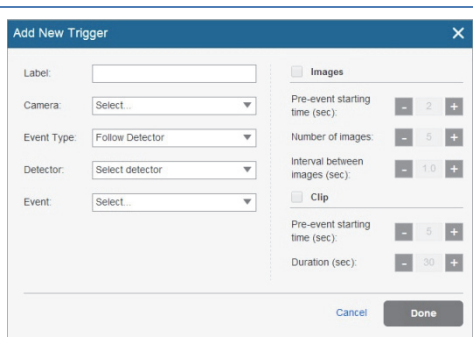
Campo	Descripción
Images	<b>Pre-event starting time (sec)</b> – tiempo previo a la ocurrencia del evento a partir del cual se comienzan a mostrar imágenes. <b>Number of images</b> – número de imágenes a mostrar. <b>Interval between images (sec)</b> – tiempo entre imágenes.
Clip	<b>Pre-event starting time (sec)</b> – tiempo previo a la ocurrencia del evento a partir del cual se comienza a grabar el video. <b>Duration (sec)</b> – duración total de la grabación de video. <b>NOTA</b> – Estos campos están actualmente bloqueados y por defecto no se pueden modificar.











6. Una vez finalizado haga clic en Done. El trigger se mostrará en la página de Camera Triggers List.

## IP Cameras

Cameras Triggers

+ Add Trigger

Label	Event	Camera	Camera Operations	Actions
Lobby floor alarm	Partition - Lobby Floor Alarm Follow	Street cam North	3 images, 10 seconds clip	  
Storage Tamper	Partition - Storage Rooms Tamper Follow	Street cam South	1 image	  
Lobby Arming	Detector - Lobby South-East Arm Follow	Lobby main cam	5 images, 20 seconds clip	  

Duplicate

Figura 16 Listado de Triggers

**NOTA** – También dispone de las opciones para cambiar , duplicar , o borrar  el trigger deseado.

**IMPORTANTE** – No se pueden definir dos triggers idénticos. Si se duplica un trigger, el evento, la cámara o ambos deben ser modificados.

# Resolución de problemas

## Configuración de Internet/Error UPnP

No todos los routers soportan la función UPnP y en algunos la opción viene deshabilitada por defecto. Si ha intentado configurar el acceso a Internet automáticamente y ha obtenido el mensaje “unable to configure Internet Access”, “UPnP Client Error” o similar, puede configurar manualmente su cámara IP con el router.

### Paso 1: Acceda al router

Use la interfaz del router para identificar la dirección IP de la cámara. Se puede acceder a la interfaz del router empleando cualquier navegador web estándar.

1. Introduzca la dirección IP local del router en la barra de direcciones del navegador web. La interfaz web se mostrará.
2. Introduzca el usuario y la contraseña y acceda a la página de administración.

**NOTA:** Para obtener más información de cómo navegar por la administración de su router por favor lea el manual de usuario del router.

3. Navegue hasta la tabla de clientes DHCP. La página con la tabla de clientes y direcciones DHCP se mostrará.

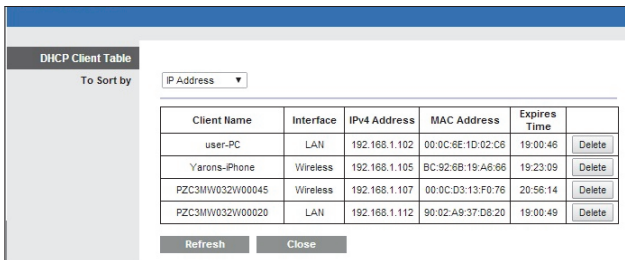

Client Name	Interface	IPv4 Address	MAC Address	Expires Time	
user-PC	LAN	192.168.1.102	00:0C:6E:1D:02:C6	19:00:46	Delete
Yaron's-Phone	Wireless	192.168.1.105	BC:92:6B:19:A6:66	19:23:09	Delete
PZC3MIV032W00045	Wireless	192.168.1.107	00:0C:D3:13:F0:76	20:56:14	Delete
PZC3MIV032W00020	LAN	192.168.1.112	90:02:A9:37:D8:20	19:00:49	Delete

Figura 17 Ejemplo de tabla de clientes DHCP

4. Tome nota de la dirección IP de la cámara que desea configurar manualmente a partir de la dirección MAC de la misma.

### Paso 2: Configuración de la cámara

Use la interfaz web de la cámara para configurarla. La interfaz web de la cámara también es accesible a través de cualquier navegador estándar.

1. Introduzca la dirección IP y el puerto de la cámara en la barra de direcciones del navegador, por ejemplo, <http://192.168.10.168:37080> (el puerto por defecto es el 37080).

**NOTA** – Cuando se use más de una cámara con el mismo router, el puerto web por defecto no puede ser el mismo.

2. Una vez que la interfaz web de la cámara se muestra, introduzca el usuario y la contraseña y haga clic en Login.

**NOTA** – Por defecto el usuario y la contraseña de la cámara es “admin” y “\_AdmiN\_+ dirección MAC” (por ejemplo, “\_AdmiN\_AABBCDDDEEFF”).

1. Una vez que la interfaz web de la cámara se ha mostrado, accede a Setup > Network > UPnP. Se mostrarán los parámetros UPnP.

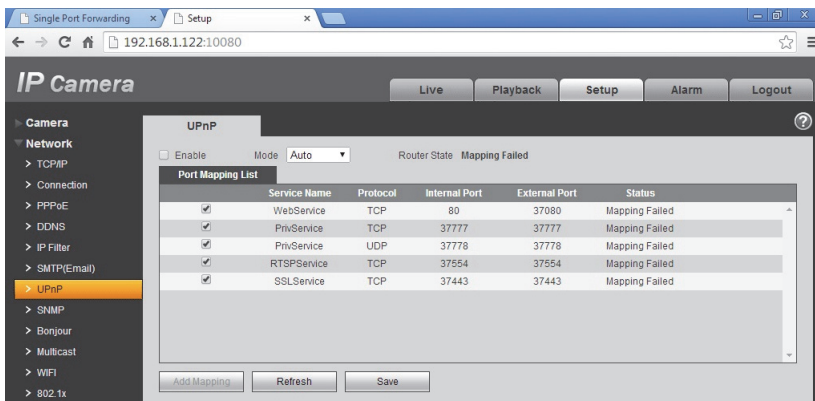

**Figura 18 Parámetros UPnP**

2. Deseleccione la opción Enable y haga clic en Save.
3. Seleccione en el menú TCP/IP.

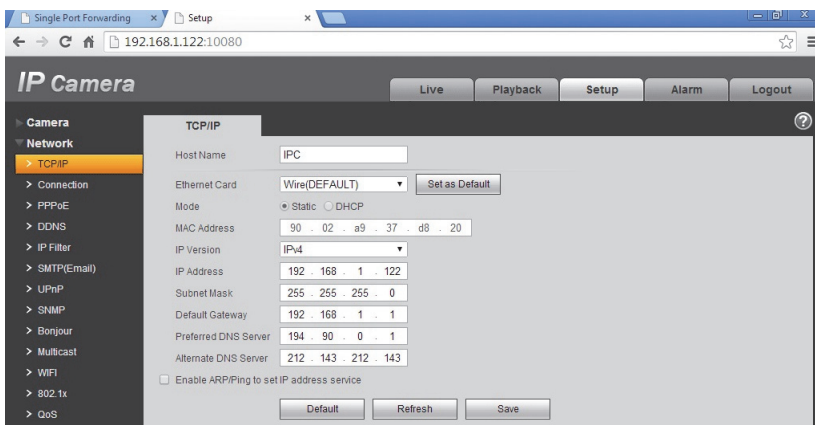

**Figura 19 Parámetros TCP/IP**

4. Seleccione la opción Static Mode e introduzca la dirección IP estática que desee para la cámara (en el ejemplo 192.168.1.122). Asimismo, configure

la máscara de red y la dirección del default gateway (en el ejemplo 255.255.255.0 y 192.168.1.1 respectivamente).

**NOTA:** Por defecto los parámetros de la configuración TCP/IP ya están definidos.

5. Haga clic en Save para guardar los cambios.
6. Seleccione en el menú Connection.

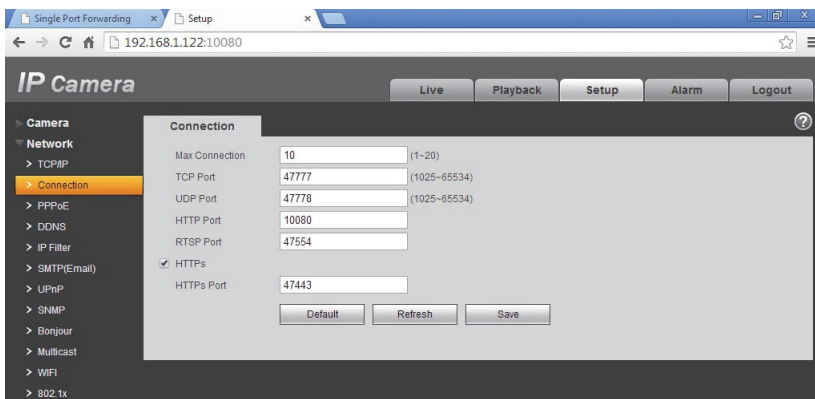

**Figura 20** Parámetros de Connection

7. Configure los siguientes puertos de la cámara:

<b>TCP Port</b>	Seleccione el puerto TCP (en el ejemplo 47777).
<b>UDP Port</b>	Seleccione el puerto UDP (en el ejemplo 47778).
<b>HTTP Port</b>	El puerto web por defecto es el 37080 y puede ser cambiado a cualquier valor entre 1024 y 65535 (en el ejemplo 10080).
<b>RTSP Port:</b>	Seleccione el puerto; el puerto por defecto es el 554 (en el ejemplo 47554).
<b>HTTPS Port</b>	El puerto web seguro por defecto es el 443 y puede ser cambiado a cualquier valor entre 1024 y 65535 (en el ejemplo 47443).

8. Haga clic en Save para guardar los cambios.
9. Repita estos pasos para todas las cámaras que desee teniendo en cuenta que no se pueden repetir los valores de los puertos.

### Paso 3: Configuración de la redirección de puertos en el router

Por defecto, las características de seguridad en muchos routers bloquean la comunicación de algunos dispositivos con Internet desde los hogares y las empresas. Para abrir un puerto se necesita habilitar la redirección de puertos en

el router. La Administración de cada router varía dependiendo de la marca y modelo del mismo, pero típicamente los pasos para abrir un puerto son similares a los siguientes:

1. Vuelva a la interfaz web del router.

**NOTA:** Para obtener más información de cómo navegar por la administración de su router por favor lea el manual de usuario del router.

2. Navegue hasta un menú que indique Port Forwarding/Port Triggering como en el ejemplo (a veces también aparece como NAT).

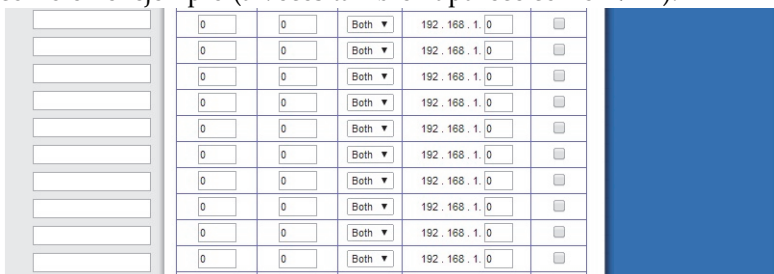

**Figura 21** Página vacía de redirección de puertos

**NOTA:** En este apartado se especifica qué IP local se corresponde con qué puertos externos. Asegúrese de habilitar el campo para la IP concreta.

3. Rellene los campos para la cámara que va a utilizar con ese router. Recuerde emplear los mismos puertos y la misma dirección IP del paso 2.

47777	47777	TCP	192.168.1.122	<input checked="" type="checkbox"/>
47778	47778	UDP	192.168.1.122	<input checked="" type="checkbox"/>
10080	10080	TCP	192.168.1.122	<input checked="" type="checkbox"/>
47554	47554	TCP	192.168.1.122	<input checked="" type="checkbox"/>
47443	47443	TCP	192.168.1.122	<input checked="" type="checkbox"/>

**Figura 22** Ejemplo de Port Forwarding

**NOTA:** Fijese en los puertos que son TCP y el puerto que es UDP.

4. Una vez terminado, grabe los cambios.
5. Reinicie la cámara desconectando y volviendo a conectar la alimentación.
6. Repita los pasos para añadir más cámaras teniendo en cuenta que no se pueden repetir ni la IP de la cámara ni los puertos.

# Especificaciones del producto

Parámetro		Valor
Sistema	Procesador	TI Davinci high performance DSP
	Sistema operativo	LINUX embebido
	Recursos del sistema	Soporta monitorización en tiempo real, grabación local y operación remota simultáneamente.
	Interfaz de usuario	WEB, DSS, PSS remoto.
	Estados del sistema	Estadísticas, log, y versión del software.
Parámetros de vídeo	Sensor	1/3-pulgada CMOS
	Pixel	1280(H)*960(V)
	Control de ganancia	Fija/Auto
	Balanceo de blancos	Manual/Auto
	BLC	Encendido/Apagado
	Exposición	Manual/Auto PAL: de 1/3 a 1/10000. NTSC: de 1/4 a 1/10000.
	Resolución	PAL: stream principal(1280*960@15fps) stream extra(352*288@15fps), stream principal (1280*720@25fps) stream extra (352*288@25fps) NTSC: stream principal (1280*960@15fps) stream extra (352*240@15fps)) stream principal (1280*720@30fps) stream extra (352*240@30fps)
	Tasa de transferencia	H.264: 56Kbps-6144Kbps MJPEG ajustable. Configuración personalizada soportada.
	Volteo de imagen	Soporta espejado. Soporta volteo.
	Capturas	Máximo 1f/s. Ficheros con extensión JPEG.
	Enmascaramiento	Soporta hasta 4 zonas de enmascaramiento.
	Configuración de vídeo	Soporta parametrización, por ejemplo, contraste y brillo.
	Información	Título del canal, hora, detección de movimiento, enmascaramiento.
	Lente	3.6mm. Fija. Ángulo de visión: 70°(H) *51.5°(V)
Interfaz	M12.	
Audio	Audio	Bidireccional.
	Entrada/Salida	Altavoz y micrófono incorporados.
	Tasa de transferencia	8kbps 16bit
	Códec	G.711A/G.711Mu/PCM
Puerto de alarma		1 canal de entrada y 1 canal de salida
Grabación y respaldo	Prioridad	Sólo soporta grabación remota. Manual>Video detect>Schedule
	Almacenamiento	Soporta MicroSD
	Gestión	Muestra el estatus del almacenamiento.
Red	Cableada	1 puerto Ethernet, 10/100 Base-T Ethernet.
	Inalámbrica	IEEE802.11a/b/g/n, antena incorporada.
	Protocolos	HTTP, TCP/IP, ARP, IGMP, ICMP, RTSP, RTP,UDP, RTCP, SMTP, FTP, DHCP, DNS, DDNS UPNP, NTP, Bonjour, SNMP.
	Operación remota	Soporta monitorización, configuración, descarga de ficheros, información de log, actualizaciones, etc.

Parámetro		Valor
Puertos AUX	Compensación de luz	Luz blanca (Máximo 1W) Soporta compensación de brillo a través de la configuración web.
	N/A	N/A
	WPS	Permite la conexión Wi-Fi con un solo botón.
Parámetros generales	Alimentación	DC 12V
	Consumo	Máximo 6W
	Operación	-10 ~+50
	Humedad	10%~90%
	Dimensiones	66.6x99.5x131.2 mm
	Peso	229 g (sin embalaje)
	Instalación	Con soporte.





# Standard Limited Product Warranty

RISCO Ltd., its subsidiaries and affiliates (“**Risco**”) guarantee Risco’s hardware products to be free from defects in materials and workmanship when used and stored under normal conditions and in accordance with the instructions for use supplied by Risco, for a period of (i) 24 months from the date of connection to the Risco Cloud (for cloud connected products) or (ii) 24 months from production (for other products which are non-cloud connected), as the case may be (each, the “**Product Warranty Period**” respectively).

**Contact with customers only.** This Product Warranty is solely for the benefit of the customer who purchased the product directly from Risco, or from any authorized distributor of Risco. Nothing in this Warranty obligates Risco to accept product returns directly from end users that purchased the products for their own use from Risco’s customer or from any installer of Risco, or otherwise provide warranty or other services to any such end user. Risco customer shall handle all interactions with its end users in connection with the Warranty, inter alia regarding the Warranty. Risco’s customer shall make no warranties, representations, guarantees or statements to its customers or other third parties that suggest that Risco has any warranty or service obligation to, or any contractual privity with, any recipient of a product.

**Return Material Authorization.** In the event that a material defect in a product shall be discovered and reported during the Product Warranty Period, Risco shall, at its option, and at customer’s expense, either: (i) accept return of the defective Product and repair or have repaired the defective Product, or (ii) accept return of the defective Product and provide a replacement product to the customer. The customer must obtain a Return Material Authorization (“**RMA**”) number from Risco prior to returning any Product to Risco. The returned product must be accompanied with a detailed description of the defect discovered (“**Defect Description**”) and must otherwise follow Risco’s then-current RMA procedure in connection with any such return. If Risco determines in its reasonable discretion that any Product returned by customer conforms to the applicable warranty (“**Non-Defective Products**”), Risco will notify the customer of such determination and will return the applicable Product to customer at customer’s expense. In addition, Risco may propose and assess customer a charge for testing and examination of Non-Defective Products.

**Entire Liability.** The repair or replacement of products in accordance with this warranty shall be Risco’s entire liability and customer’s sole and exclusive remedy in case a material defect in a product shall be discovered and reported as required herein. Risco’s obligation and the Warranty are contingent upon the full payment by customer for such Product and upon a proven weekly testing and examination of the product functionality.

**Limitations.** The Product Warranty is the only warranty made by Risco with respect to the Products. The warranty is not transferable to any third party. To the maximum extent permitted by applicable law, the Product Warranty does not apply and will be void if: (i) the conditions set forth above are not met (including, but not limited to, full payment by customer for the product and a proven weekly testing and examination of the product functionality); (ii) if the Products or any part or component thereof: (a) have been subjected to improper operation or installation; (b) have been subject to neglect, abuse, willful damage, abnormal working conditions, failure to follow Risco’s instructions (whether oral or in writing); (c) have been misused, altered, modified or repaired without Risco’s written approval or combined with, or installed on products, or equipment of the customer or of any third party; (d) have been damaged by any factor beyond Risco’s reasonable control such as, but not limited to, power failure, electric power surges, or unsuitable third party components and the interaction of software therewith or (e) any delay or other failure in performance of the product

attributable to any means of communications, provided by any third party service provider (including, but not limited to) GSM interruptions, lack of or internet outage and/or telephony failure. BATTERIES ARE EXPLICITLY EXCLUDED FROM THE WARRANTY AND RISCO SHALL NOT BE HELD RESPONSIBLE OR LIABLE IN RELATION THERETO, AND THE ONLY WARRANTY APPLICABLE THERETO, IF ANY, IS THE BATTERY MANUFACTURER'S WARRANTY. Risco makes no other warranty, expressed or implied, and makes no warranty of merchantability or of fitness for any particular purpose. For the sake of good order and avoidance of any doubt:

**DISCLAIMER.** EXCEPT FOR THE WARRANTIES SET FORTH HEREIN, RISCO AND ITS LICENSORS HEREBY DISCLAIM ALL EXPRESS, IMPLIED OR STATUTORY, REPRESENTATIONS, WARRANTIES, GUARANTEES, AND CONDITIONS WITH REGARD TO THE PRODUCTS, INCLUDING BUT NOT LIMITED TO ANY REPRESENTATIONS, WARRANTIES, GUARANTEES, AND CONDITIONS OF MERCHANTABILITY, FITNESS FOR A PARTICULAR PURPOSE, TITLE AND LOSS OF DATA. WITHOUT LIMITING THE GENERALITY OF THE FOREGOING, RISCO AND ITS LICENSORS DO NOT REPRESENT OR WARRANT THAT: (i) THE OPERATION OR USE OF THE PRODUCT WILL BE TIMELY, SECURE, UNINTERRUPTED OR ERROR-FREE; (ii) THAT ANY FILES, CONTENT OR INFORMATION OF ANY KIND THAT MAY BE ACCESSED THROUGH THE PRODUCT BY CUSTOMER OR END USER SHALL REMAIN SECURED OR NON DAMAGED. CUSTOMER ACKNOWLEDGES THAT NEITHER RISCO NOR ITS LICENSORS CONTROL THE TRANSFER OF DATA OVER COMMUNICATIONS FACILITIES, INCLUDING THE INTERNET, GSM OR OTHER MEANS OF COMMUNICATIONS AND THAT RISCO'S PRODUCTS, MAY BE SUBJECT TO LIMITATIONS, DELAYS, AND OTHER PROBLEMS INHERENT IN THE USE OF SUCH MEANS OF COMMUNICATIONS. RISCO IS NOT RESPONSIBLE FOR ANY DELAYS, DELIVERY FAILURES, OR OTHER DAMAGE RESULTING FROM SUCH PROBLEMS.

RISCO WARRANTS THAT ITS PRODUCTS DO NOT, TO THE BEST OF ITS KNOWLEDGE, INFRINGE UPON ANY PATENT, COPYRIGHT, TRADEMARK, TRADE SECRET OR OTHER INTELLECTUAL PROPERTY RIGHT  
IN ANY EVENT RISCO SHALL NOT BE LIABLE FOR ANY AMOUNTS REPRESENTING LOST REVENUES OR PROFITS, PUNITIVE DAMAGES, OR FOR ANY OTHER INDIRECT, SPECIAL, INCIDENTAL, OR CONSEQUENTIAL DAMAGES, EVEN IF THEY WERE FORESEEABLE OR RISCO HAS BEEN INFORMED OF THEIR POTENTIAL.

Risco does not install or integrate the product in the end user security system and is therefore not responsible for and cannot guarantee the performance of the end user security system which uses the product.

Risco does not guarantee that the product will prevent any personal injury or property loss by burglary, robbery, fire or otherwise; or that the product will in all cases provide adequate warning or protection.

Customer understands that a correctly installed and maintained alarm may only reduce the risk of burglary, robbery or fire without warning, but is not an assurance or a guarantee that such an event will not occur or that there will be no personal injury or property loss as a result thereof. Consequently Risco shall have no liability for any personal injury, property damage or loss based on a claim that the product fails to give warning.

No employee or representative of Risco is authorized to change this warranty in any way or grant any other warranty.

**RTTE Compliance Statement:**

Hereby, RISCO Group declares that this equipment is in compliance with the essential requirements and other relevant provisions of Directive 1999/5/EC. For the CE Declaration of Conformity please refer to our website: [www.riscogroup.com](http://www.riscogroup.com).

# Contacting your Installer / Supplier-Agent

When calling for service, ordering components, or for questions related to your camera, please contact us for assistance:

**Company/agent address,  
phone, e-mail address:** \_\_\_\_\_

**Contact / department:** \_\_\_\_\_

**Hours of business:** \_\_\_\_\_

**Website URL:** \_\_\_\_\_

**Company logo:** \_\_\_\_\_

**Other supplier-specific  
information:** \_\_\_\_\_

## Contacting RISCO Group

RISCO Group is committed to customer service and product support. You can contact us through our website ([www.riscogroup.com](http://www.riscogroup.com)) or at the following telephone and fax numbers:

### United Kingdom

Tel: +44-(0)-161-655-5500  
[support-uk@riscogroup.com](mailto:support-uk@riscogroup.com)

### Belgium (Benelux)

Tel: +32-2522-7622  
[support-be@riscogroup.com](mailto:support-be@riscogroup.com)

### China (Shenzhen)

Tel: +86-755-82789285  
[support-cn@riscogroup.com](mailto:support-cn@riscogroup.com)

### Italy

Tel: +39-02-66590054  
[support-it@riscogroup.com](mailto:support-it@riscogroup.com)

### USA

Tel: +1-631-719-4400  
[support-usa@riscogroup.com](mailto:support-usa@riscogroup.com)

### Poland

Tel: +48-22-500-28-40  
[support-pl@riscogroup.com](mailto:support-pl@riscogroup.com)

### Spain

Tel: +34-91-490-2133  
[support-es@riscogroup.com](mailto:support-es@riscogroup.com)

### Brazil

Tel: +55-11-3661-8767  
[support-br@riscogroup.com](mailto:support-br@riscogroup.com)

### Israel

Tel: +972-3-963-7777  
[support@riscogroup.com](mailto:support@riscogroup.com)

### France

Tel: +33-164-73-28-50  
[support-fr@riscogroup.com](mailto:support-fr@riscogroup.com)

### China (Shanghai)

Tel: +86-21-52-39-0066  
[support-cn@riscogroup.com](mailto:support-cn@riscogroup.com)

### Australia

Tel: +1800-991-542  
[support-au@riscogroup.com](mailto:support-au@riscogroup.com)



All rights reserved.

No part of this document may be reproduced in any form without prior written permission from the publisher.